

C E M I N T E L<sup>®</sup>  
T E R R I T O R Y<sup>™</sup>

NEW ZEALAND DESIGN AND INSTALLATION GUIDE



## TABLE OF CONTENTS

|   |           |  |           |
|---|-----------|--|-----------|
| <b>01 INTRODUCTION</b>                      | <b>1</b>  | <b>06 SYSTEM ENGINEERING</b>               | <b>19</b> |
| Introduction                                | 1         | Design, Detailing and Performance          |           |
| <b>02 PRODUCT OVERVIEW</b>                  | <b>2</b>  | Responsibilities                           | 20        |
| Panel Information                           | 3         | Span Tables / Wind Loads                   | 21        |
| Colour Palette                              | 4         | Masonry Substrates                         | 23        |
| <b>03 SYSTEM OVERVIEW</b>                   | <b>5</b>  | <b>07 INSTALLATION</b>                     | <b>24</b> |
| Applications                                | 7         | Prior to Installation                      | 25        |
| Benefits of the Cemintel Territory System   | 7         | Installation Set-Out                       | 26        |
| Product Specifications/System Solutions     | 7         | Steel Framing                              | 28        |
| <b>04 DESIGN + AESTHETIC CONSIDERATIONS</b> | <b>8</b>  | Masonry Framing                            | 30        |
| General                                     | 9         | Installation for Timber and Steel Framing  | 33        |
| Control Joints                              | 10        | Installation for Masonry                   | 35        |
| Structural                                  | 11        | <b>08 CONSTRUCTION DRAWINGS + DETAILS</b>  | <b>36</b> |
| Weatherproofing                             | 11        | <b>09 SAFETY, HANDLING + GENERAL CARE</b>  | <b>55</b> |
| Wall Wrap/Sarking Moisture Management       | 12        | Health, Safety and PPE                     | 56        |
| Insulation and Energy Efficiency            | 13        | Handling & General Care                    | 56        |
| Extreme Climate Conditions                  | 13        | <b>10 WARRANTY, CLEANING + MAINTENANCE</b> | <b>57</b> |
| Other Design Considerations                 | 14        | Warranty                                   | 58        |
| <b>05 COMPONENTS + ACCESSORIES</b>          | <b>15</b> | Wash Down Process                          | 58        |
|   |           | Inspection, Repair and Maintenance         | 58        |

## Introduction

Cemintel's Territory cavity walling system combines a prefinished panel with a simple installation system that can be used externally or internally for residential and commercial buildings.

This Design and Installation Guide recommends good building practice methodology and has been prepared as a general guide of design considerations, system engineering information and installation procedures for common external horizontal applications. It assumes that the user has an intermediate knowledge level of building design and construction. In no way does it replace the services of the building professionals required to design projects, nor is it an exhaustive guide of all possible scenarios. It is the responsibility of the architect, designer and

various engineering parties to ensure that the details in this Design and Installation Guide are appropriate for the intended application.

Territory can be installed either horizontally or vertically, externally or internally. This guide refers to **external horizontal installations** only as components differ depending on the installation.

Refer to the 'Design and Installation Guide for Cemintel Territory External Vertical Installation' or the 'Design and Installation Guide for Cemintel Territory Internal Installation' for instructions regarding these applications.

A large, stylized graphic of the number '022' in a light gray, outlined font, positioned in the lower half of the page. The '0' is a simple oval, the first '2' has a curved top, and the second '2' is more angular.

# PRODUCT OVERVIEW

## Panel Information

Cemintel Territory panels are cement bonded fibrous wood particle products that are pressed with a surface texture. They are cut to a standard length of 3030mm with an effective cover width of 455mm and 16mm nominal thickness. The horizontal edges of the panel are machined with a complementary tongue and groove profile. A compressible sealing strip is bonded onto the tongue which enables the panels to fit neatly together to form a weather resistant joint.

The panels have been pre-finished using a durable multi-layered paint process to simulate a range of textured finishes, for example, timber, concrete, stone or render. They are ready-to-install and are highly durable.

Panels have a special NichiGuard® self cleaning coating\* applied during the manufacturing process to Japanese standards. Panels include Platinum Coating technology to protect against UV damage and colour fade.

There is a range of colour matched accessories including pre-formed external corner profiles, joint sealants and touch up paint kits to speed installation and enhance the project finish and appearance.

An alternative aluminium corner can also be used for a more contemporary aesthetic.

\*Note: not all panels have NichiGuard self cleaning coating – check Technical Data Sheet.

FIGURE 2.01

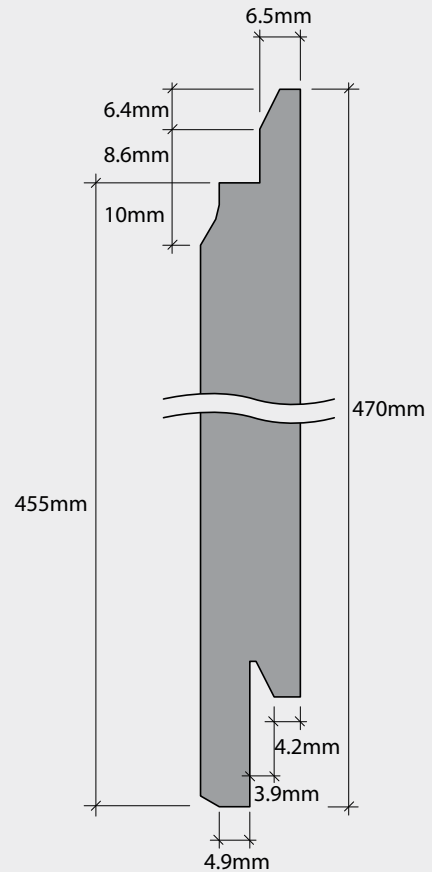



PRODUCT OVERVIEW



**NZ Stocked Colour Palette**

**S** = Stocked **I** = Indent

**Woodlands**



**Quarry**



**Ridge**



**Canyon**



**Savanna**



As Territory is a prefinished product, product images may vary from the actual product in regard to colour and surface finish. Panels should be inspected by the owner prior to installation to ensure they meet aesthetic requirements.

Indent only products require additional lead times and have minimum order quantities.

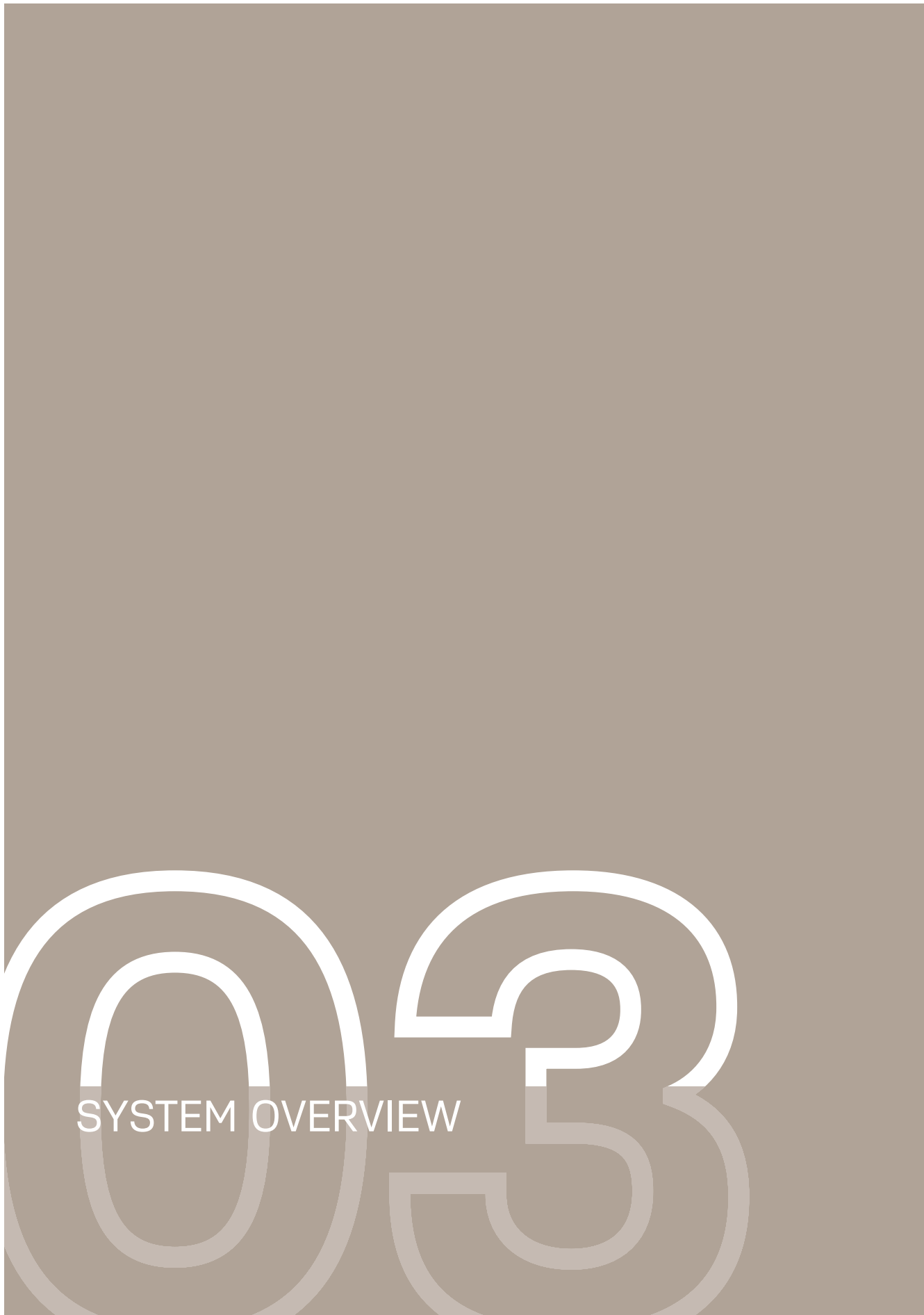

SYSTEM OVERVIEW

## SYSTEM OVERVIEW



**FIGURE 3.01** Cemintel Territory panels are installed with the unique Designer Series clip system – providing a ventilated cavity.

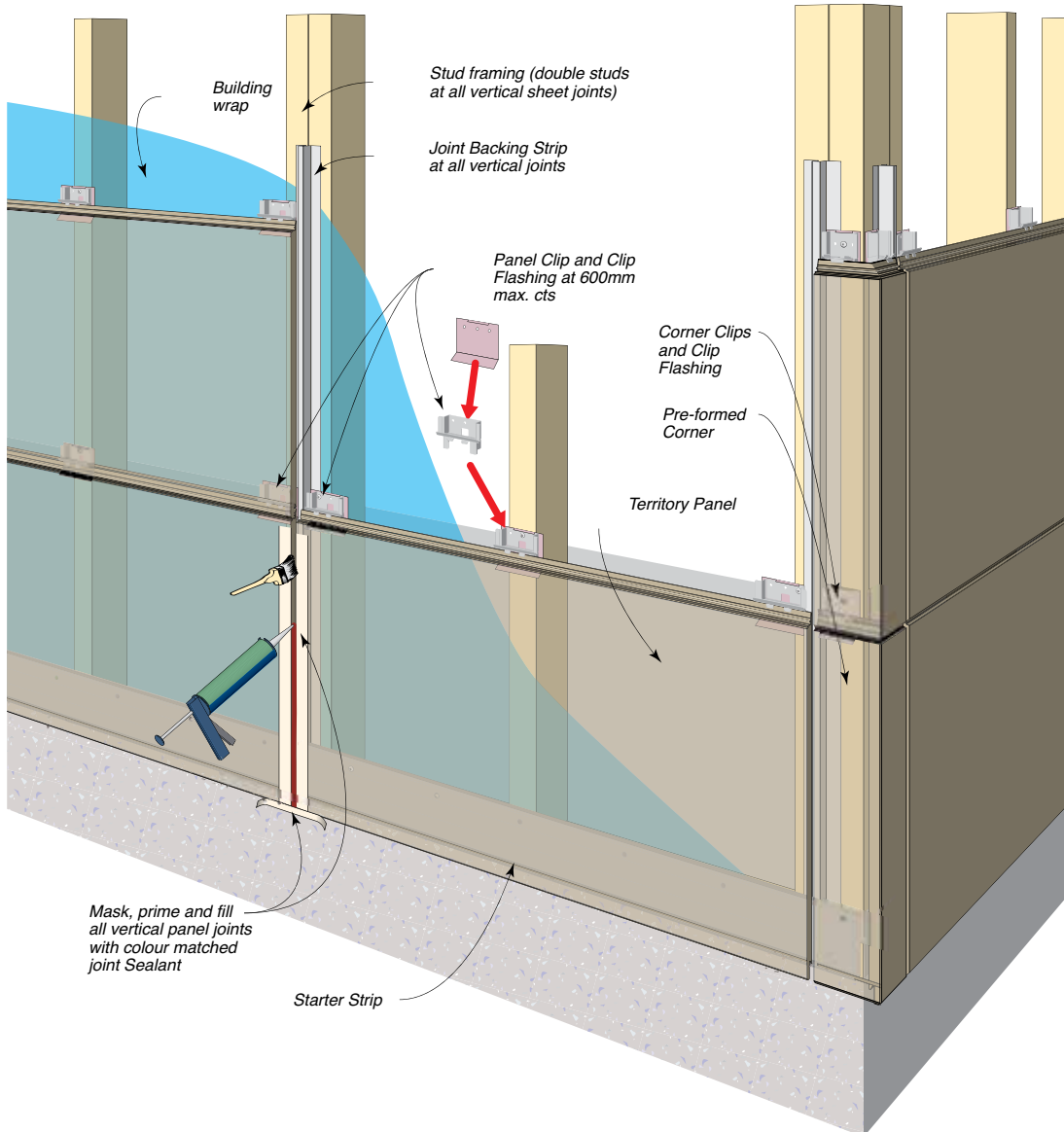

Designer Series clips, together with spacer strips, base starter strips and head vents/eaves trims, create a 15mm cavity behind the Territory panels which allows air flow, ventilation and drainage. This prevents moisture build up and reduces the risk of moisture penetration, allowing the building shell to dry out, creating a healthier, more breathable building.

Aluminium corners can be used as an alternative to the pre-formed corners shown above.



## 03

## SYSTEM OVERVIEW



### Applications

Cemintel Territory is suitable for all building classes, however, site environmental factors such as wind pressures and corrosivity zones need to be taken into account to determine its suitability for a particular environment.

Codemark Certificate of Conformity No. GM-CM30041 has been obtained for installation to timber, steel and masonry frames. The Certificate confirms compliance with NZ Building Code clauses relating to structure, weather resistance, bushfire construction and thermal resistance.

When installed horizontally, the panels and system have been tested to withstand wind pressures up to 6kPa.



### Benefits of the Cemintel Territory System

- Low maintenance.
- No requirement for additional painting costs.
- Potential to speed up the construction process.
- Large format lightweight panels are designed to be fixed to industry standard timber or steel stud structural frames.
- Can also be fixed to masonry.
- Ventilated cavity system allows air flow and drainage.
- Panels are easy to cut for openings eg. around windows and meter boxes.
- Fire Resistance – has been assessed as a Type A cladding.
- Durable and weather resistant;
  - Provides effective protection against wind, rain and temperature extremes, mould and mildew
  - Panels will not rot, swell or warp when correctly installed and maintained
- Suitable for Sea Spray Zone D.

### Product Specifications/System Solutions

A technical Data Sheet can be downloaded from [cemintel.co.nz](http://cemintel.co.nz)

| Dimensional/Geometrical Characteristic | Specification   | Manufacturing Tolerance | Relevant Standard             |
|--|---|-------------------------|-------------------------------|
| Panel Width                            | 470mm (overall width)<br>455mm (effective coverage)   | + / - 1mm               | JIS A 5422                    |
| Panel Length                           | 3030mm  | + / - 1mm               | JIS A 5422                    |
| Panel Thickness                        | 16mm  | + / - 1.2mm             | JIS A 5422                    |
| Panel Weight (EMC)                     | Between 24.6kg and 30kg per panel. Weight varies depending on finish. (Note: 2 panels per pack)   |                         |                               |
| Fire Safety Cladding Type              | Type A  |                         | C/VM2 Appendix 2/<br>ISO 5660 |
| Weatherproofing                        | Has passed testing for Wind zones up to and including Extra High and a serviceability wind pressure of +3.72 kPa. (Rigid Air Barrier recommended for pressures above 1.5 kPa and Extra High Wind zones) |                         | AS/NZS 4284<br>& E2/VM1       |
| Wind load                              | Suitable for use in Wind zones up to and including Extra High and for ultimate wind load of +/- 6.0 kPa.  |                         | AS/NZS 1170.2<br>& NZS 3604   |

DESIGN + AESTHETIC CONSIDERATIONS



DESIGN + AESTHETIC  
CONSIDERATIONS



## 04

## DESIGN + AESTHETIC CONSIDERATIONS

This section outlines some important areas for consideration in determining whether Cemintel Territory is suitable for the required application. The following points are not exhaustive. It is the responsibility of the Architect/building designer to ensure the design conforms to NZBC requirements and other relevant building standards that may exist for the location. This guide should be read in conjunction with the NZBC.

### Face Fixings

Cemintel Territory is installed largely as a concealed fixing system. The panels are held in place by clips that are screwed to the frame. However, in some places, for example, around openings where clips cannot be fixed, face fixed nails or screws are used. A colour matched touch up paint is available to cover the nails or screws in this instance. Further, depending on wind loads, there may be a requirement for extra face fixings (refer to Fig 4.01). **Do NOT use sealant on nail heads.**

**FIGURE 4.01** Typical Territory System Cross Sectional

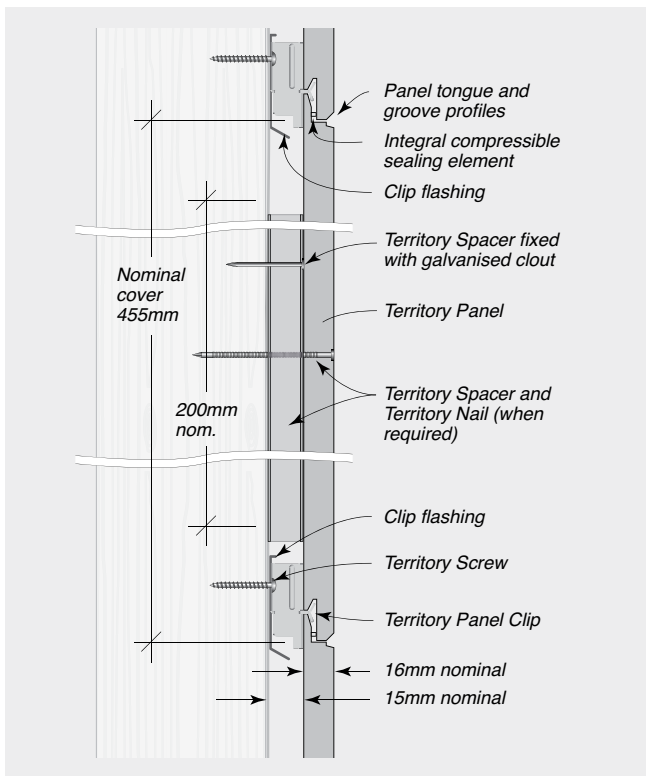

Detail where Face fixing is required – Elevation

### Coverage

A Cemintel Territory panel has a nominal width coverage of 455mm.

Note that the recommended minimum cut panel size is 100mm in length and 200mm in height. Anything under this will most likely result in cracking. **All cut panels must have exposed edges sealed to protect against moisture penetration.**

### Window & Door Openings

Cemintel Territory is compatible with industry standard aluminium and timber framed windows. Aluminium windows **MUST NOT** have sill drain holes that can direct water into the wall cavity.

With the cavity created by the clip system, particular attention needs to be given to the set out of windows and doors.

The depth of the window needs to be taken into account in the design of the building frame so that the front face of the panel is properly aligned with the window and that the flashing is installed correctly.

A nominal space of 31mm needs to be allowed for a flush finish – taking into account the 15mm cavity (created through the use of the starter strip, clips and spacers) and 16mm panel thickness. This needs to be included in drawings for any project.

If using a rigid air barrier, the thickness of this also needs to be accounted for to achieve a flush finish when determining window set out and reveal depths.

Refer to window detail drawing options in 'Construction Drawings and Details' section of this guide.

### Eaves Junction

Options are provided to ensure air circulation through the cavity. A proprietary foam 'L Form Vent' can be concealed behind a traditional timber trim. Alternatively, a coloured metal Eave Trim is available with matching external corner pieces. It is not recommended that air be vented into the roof space.

### Corners

The system offers the choice of either pre-formed matching corners or metal corners. In many cases the metal corners are considered easier to install. Note that metal corners are recommended when installing onto masonry.

Panel Coverage Calculator.

| Territory Panel Rows (Height) | Coverage for Full Panels (mm nominal) |
|-------------------------------|---------------------------------------|
| 1                             | 455                                   |
| 2                             | 910                                   |
| 3                             | 1365                                  |
| 4                             | 1820                                  |
| 5                             | 2275                                  |
| 6                             | 2730                                  |
| 7                             | 3185                                  |
| 8                             | 3640                                  |
| 9                             | 4095                                  |

## DESIGN + AESTHETIC CONSIDERATIONS



## Control Joints

### Movement Control Joints

Control joints provided in the panel layout should be aligned with any movement control joints provided in the framing. For example, a horizontal control joint of approximately 20-30mm may be required at every storey junction (Refer to Fig 4.02).

When undertaking building additions, a movement control joint must be installed at the junction of the existing framing and new framing. The cladding systems must be discontinuous at this joint. Refer to 'Construction Drawings and Details' section.

When setting out panels, design consideration should be given to the location of joints to ensure that minimum panel lengths and widths are met.

### Horizontal Control Joints

Where frame shrinkage may be a concern, Cemintel NZ recommends creating a horizontal break in the panelling at the first floor level or by incorporating a verandah or awning or other design element to create discontinuous panelling.

### Vertical Control Joints

Vertical sealant filled control joints are required at the end of each panel (at a maximum 3030mm spacings = full length panel), at junctions with pre-formed corners, and at other wall junctions. No additional vertical control joints are required.

Vertical joints in panels must be aligned and extend for the full height of continuous panelling, although additional joints may be placed over openings for ease of installation. As the joints are expressed and sealant filled, consideration to the positioning of joints is important for aesthetic reasons. Placing joints at sides or above openings, or the use of full height windows can reduce the visual impact of joints.

A vertical control joint must also be installed when a masonry wall adjoins framed construction, and at the junction of framed additions to existing buildings, to allow for differential movement. Refer to 'Construction Drawings and Details' section.

**FIGURE 4.02** Typical layout of vertical and horizontal panel joints.

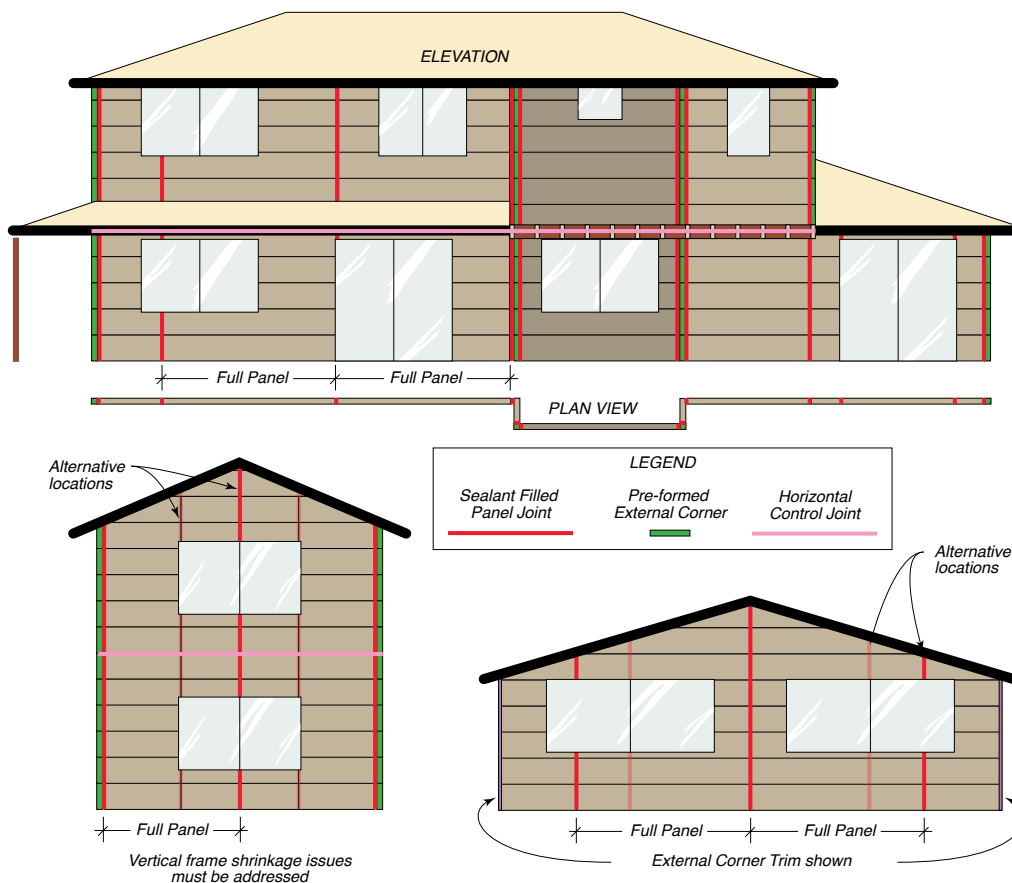



## DESIGN + AESTHETIC CONSIDERATIONS

### Structural

#### Windload

Wind loads have been calculated in accordance with AS/NZS1170.2 and for wind zones described in NZS 3604. Span tables are provided for timber framing and steel framing, suitable for all New Zealand wind zones and wind pressures of up to 6kPa.

The tables assume that an interior lining is in place so that only exterior pressures are applied to the cladding. The interior linings must be designed for the appropriate pressures. Contact Cemintel NZ for information on buildings requiring specific design.

#### Framing and Substrate Options

Cemintel Territory can be fixed to timber or steel framing as well as to masonry substrates.

For timber and steel framing, the minimum requirement shall be in accordance with the following standards:

- NZS 3604 – Timber Framed Buildings.
- NZS 3404 – Steel Structures.
- AS/NZS4600 – Cold Formed Steel Structures.

The Territory horizontal installation has been evaluated for use in all New Zealand wind zones up to and including Extra High in accordance with NZS3604, and for wind pressures up to 6kPa for projects outside the scope of NZS3604.

It is critical that the frame is true and plumb. Industry best practice for frame tolerance is 5mm misalignment over 3000mm.

Note: depending on the chosen panel layout, double studs may be required in some locations. Refer to 'System Engineering' section.

#### Masonry Installation

Masonry structures are potentially more likely to be out of plumb. This guide provides a fixing solution for masonry however, the top hat has limited ability to allow for variation in the surface plane. Careful assessment should be undertaken to determine if this solution is appropriate for the specific situation.

Span tables are located in 'System Engineering' section.

#### Structural Bracing

Cemintel Territory panels are indirectly attached to the structural framing using clips and spacers. As a consequence, they are not designed to provide wall bracing.

Bracing must be provided in the structural framing with methods such as sheet or strap bracing. Where sheet bracing is used, the entire wall framing to be clad with Territory panels must be sheeted to maintain a uniform fixing plane. Note: window setout will be affected.

If the building requires a rigid air barrier for weatherproofing purposes (ie higher wind load areas), it is possible to use 6mm fibre cement sheeting as part of the bracing system. Contact Cemintel NZ for options.

#### Thermal Break

A thermal break with a minimum R-value of R0.25 is required where Cemintel Territory is fixed to steel framing of walls enclosing habitable or usable spaces. The thermal break is applied to the face of the frame to ensure that the performance of the wall complies to Acceptable Solution E3/AS1 Internal Moisture as condensation control.

## DESIGN + AESTHETIC CONSIDERATIONS



### Weatherproofing

- The Territory range has been weather tested to E2/VM1 to successfully withstand water ingress for Wind Zones up to and including Extra High. For Extra High wind zones a Rigid Air Barrier is required.
- The Territory range has been weather tested to AS/NZS 4284 to successfully withstand water ingress for serviceability wind loads of up to +3.72kPa and -3.72kPa and to withstand ultimate wind loads of +6kPa and -6kPa. A specific air barrier is required and options are available with wall wraps/sarking (ultimate wind load up to 1.5kPa) and with a rigid air barrier. Refer to 'System Engineering' Section and Cemintel's Design and Installation Guide for Rigid Air Barrier for further information.
- Windows must be a front draining style and have appropriate flashing to prevent moisture ingress.
- It is important to seal any exposed cut edges to protect against moisture penetration into the panel.

### Wall Wrap for Moisture Management

All buildings require an air barrier to be installed. This may be wall wrap, fibre cement, ply wood or masonry. Installation of fibre cement is detailed in the Cemintel Air Barrier Design and Installation Guide. Masonry substrates must be sealed to act as an air barrier for an effective waterproofing system. For residential buildings in wind zones Low to Very High, wall wrap may generally be used (install as per manufacturer's requirements).

Installation of a wall wrap is required over the structural frame before the panels are fixed. Where the building is in an Extra High wind zone or required to withstand wind loads in excess of 1.5kPa, a rigid air barrier is required in lieu of wall wrap. To ensure occupant comfort and protection of the building frame, the following factors should be considered during the selection of the correct wall wrap:

Building wrap (flexible underlay) is an integral part of the Territory system, and must be combined

with a rigid wall underlay in wind zone Extra High. Wind forces can produce lower air pressures within buildings than on the outside, assisting to force water through gaps in the building envelope such as around penetrations and joints, even at low wind speeds.

The system incorporates a drained cavity, similar to brick veneer construction. This is highly effective at removing condensation and any incidental moisture from the cavity, thereby ensuring that the components within the cavity can dry out. The underlay must be installed in accordance with the Acceptable Solution E2/AS1.

Condensation is a complex problem, and can occur under a variety of conditions, not just cold weather. Literature on this subject is available from CSIRO/BRANZ/ASHRAE/ABCBand should be consulted when building in areas where condensation is likely to occur.



## DESIGN + AESTHETIC CONSIDERATIONS

### Insulation and Energy Efficiency

Thermal insulation values for walls must be calculated in order to meet the energy efficiency requirements of NZBC Clause H1.

Calculation tools are available (BRANZ) based on the methods of NZS 4218 for the total insulation values for walls, based on the climate zone (as shown in Appendix B of NZS 4218) and the construction R-values of the building wall elements. Construction

R-values should be calculated in accordance with NZS 4214 Methods of determining the total thermal resistance of parts of buildings.

Further information can be found in Acceptable Solution H1/AS1 and the BRANZ House Insulation Guide.

### Solar Reflectance/Absorptance

In some states, it is a requirement to provide solar values for coloured product.

Cemintel Territory has been tested by the University of New South Wales to determine Solar Absorption and Reflectance as required by the NZBC. The products have been tested to ASTM E 903-96 'Standard Test Method for Solar Absorptance, Reflectance and Transmittance of Materials Using Integrating Spheres'.

Current values are included in the Technical Data Sheet.

### Extreme Climate Conditions

#### Corrosive Zones

Consideration of corrosivity zones should be taken into account. While Territory panels are not susceptible to corrosion, consideration needs to be made regarding the impact of climate conditions on system components such as fasteners, clips and metal framing, for example.

Corrosivity zones are described in NZS 3604, with further information available in AS/NZS 2728 and E2/AS1. It is recommended that the building designer assess the site in accordance with the standards and local conditions to determine suitability of the system.

The Territory system may be used in zones B, C and D except for fixing to masonry which is limited to zones

B & C. The System is not suitable for use in Zone E or in industrial and geothermal areas where the environment may be acidic with a pH of less than 5.

In all zones, all walls which are protected by soffits above must be washed down twice per year, to remove salt and debris buildup, particularly around window/door openings.

#### Temperature Extremes

Territory panels are not warranted for use in freezing conditions in which panels are in contact with snow or extremely hot temperatures (above 50°C).

### Other Design Considerations

#### Penetrations

Penetrations in the Territory panels must be neatly cut using appropriate tools such as a saw, drill or hole saw.

Penetrations should be prepared with a clearance of 8-10mm all around and the gap must be fully sealed with sealant.

Elements that cross the cavity must not allow water to transfer to the building wrap, for example, by angling them down to the cladding.

#### Renovations and Additions

When undertaking building renovations, remove all cladding and wall wrap/sarking and insulation from the original wall framing. Ensure the condition of the



## DESIGN + AESTHETIC CONSIDERATIONS



framing is in accordance with current requirements and is as true and as plumb as possible (within accepted industry tolerance of 5mm misalignment over 3000mm).

Install additional framing as required, insulation, air barrier and flashing.

When undertaking building additions, a movement control joint must be installed at the junction of the current framing and new framing. The current and new framing and cladding systems must be discontinuous at this control joint.

#### Limitations

The Territory system is NOT suitable for the following applications: Panels with non-vertical face (e.g. Parapet Capping); wet areas such as bathrooms and water features; exposure to temperatures over 50°C; non-vented parapet cladding; contact with standing snow or ice.

Do NOT apply tiles or other materials to the face of the panels.

#### Fire Safety Requirements

All cladding for buildings over 7m high requires a fire test in accordance with ISO 5660. Territory panels have been tested by BRANZ to achieve a 'Type A' Cladding Type. This allows Territory panels to be installed on buildings above 7m to achieve fire safety requirements. Cemintel NZ also recommend installing horizontal cavity barriers to reduce the risk of fire spread via the facade. Cavity barriers must not block water drainage or air flow paths.

It is the responsibility of the building designer, architect or engineer to meet these requirements.

#### Territory QUARRY Urban Grey

Note that the Territory QUARRY Urban Grey panel has "dimples" across the surface to replicate the look of formwork and these need to be considered in the design phase. Extra product may need to be ordered accordingly. The Territory QUARRY Concrete has the same colour/finish but has a flat profile (ie no "dimples").

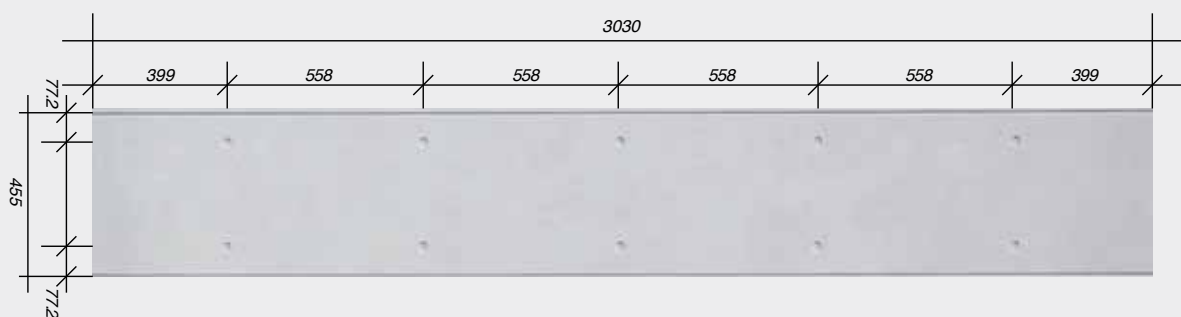

# 05

COMPONENTS + ACCESSORIES

## COMPONENTS + ACCESSORIES



Note: Codes can change from time to time. Refer to the website for the current list of components prior to ordering.

## Cemintel Territory Panels and Colour Matched Accessories

| Product Name - NZ Stocked range | Panel (2 Pk) | Touch-Up Paint* | Primer | Pre-formed External Corner # |
|---------------------------------|--------------|-----------------|--------|------------------------------|
| WOODLANDS Teak                  | 133975       | 487025          | 111616 | 140727                       |
| WOODLANDS Grey Gum              | 472376       | 487057          | 111616 | 472325                       |
| WOODLANDS Ebony                 | 163108       | 487026          | 111616 | 163109                       |
| WOODLANDS Jarrah Slats          | 472360       | 487060          | 111616 | 472328                       |
| WOODLANDS Kwila Slats           | 472361       | 487061          | 163172 | 472329                       |
| WOODLANDS Oaky Slats            | 472362       | 487062          | 111616 | 472330                       |
| QUARRY Urban Grey               | 133977       | 487024          | 111616 | 134410                       |
| QUARRY Concrete                 | 134702       | 487024          | 111616 | 134410                       |
| QUARRY Mottled Rustic Brick     | 472367       | 487063          | 111616 | 472331                       |
| QUARRY Black Modern Brick       | 472375       | 487064          | 111616 | 484737                       |
| RIDGE Black                     | 472373       | 487068          | 163172 | 472336                       |
| RIDGE White                     | 472374       | 487067          | 111616 | 472337                       |
| CANYON Kings                    | 472363       | 487073          | 111616 | 472338                       |
| CANYON Katherine                | 472364       | 487072          | 111616 | 472339                       |
| CANYON Carnavon                 | 472365       | 487074          | 111616 | 472340                       |
| SAVANNA Cloud                   | 133935       | 487018          | 111616 | 134391                       |
| SAVANNA Haze                    | 133936       | 487019          | 111616 | 140726                       |







| Product Name - Indent Only Range | Panel (2 Pk) | Touch-Up Paint* | Primer | Pre-formed External Corner # |
|----------------------------------|--------------|-----------------|--------|------------------------------|
| WOODLANDS Smoked                 | 133976       | 487034          | 111616 | N/A                          |
| WOODLANDS Cedar                  | 472377       | 487059          | 163172 | 472326                       |
| WOODLANDS Limed                  | 163175       | 487036          | 111616 | 163225                       |
| WOODLANDS Birch                  | 472366       | 487058          | 163172 | N/A                          |
| QUARRY Grey Rustic Brick         | 472368       | 487066          | 111616 | 484736                       |
| QUARRY White Rustic Brick        | 487050       | 487065          | 111616 | 472333                       |

\*Touch-Up Paint - use for nail heads, cut edges at window heads and other visible blemishes.

If 304 nail heads require coating, use a primer for bare steel such as Dulux All Metal Primer prior to coating with the appropriate colour matched paint.

#Pre-formed External Corners are manufactured to match panels. Internal measurement - 70mm x 70mm. Coverage nominal 86mm x 86mm x 455mm.

## Other Accessories/Tools

| Accessories   | Description   | Size | Quantity     | Product Code |
|---|---|------|--------------|--------------|
|  | <b>Screws for timber framing</b> - used to fix starter strip, clips and other components. Stainless steel 410 grade and clear coated.   | 35mm | 250 per pack | 487015       |
|  | <b>Screws for timber framing</b> - for fixing components over materials such as rigid air barrier or bracing sheet. Galvanised steel, Cat5 ArmaGalv.  | 63mm | 250 per pack | 487041       |
|  | <b>Nails for timber framing</b> - for fixing Territory panels at soffit line and other locations where required. Ribbed shank, flat head, stainless steel 304 grade. Pre-drill panels for all nails.  | 75mm | 115 per pack | 487016       |
|  | <b>Screws for steel framing</b> - for fixing starter strip, clips and other components. Cat5 ArmaGalv, 8g, self-drilling, button head, Phillips drive.  | 40mm | 250 per pack | 487027       |
|  | <b>Screws for steel framing</b> - for face fixing Territory panels at soffit line and other specified locations. Cat5 ArmaGalv, self-drilling, CSK self-embedding head, Phillips drive. Suitable for 0.75mm BMT steel framing.                          | 75mm | 100 per pack | 487028       |
|  | <b>Screws for masonry framing</b> - for fixing start strip, clips and other components onto Rondo H515 Top Hats. Class 3, 8g, self-drilling, wafer head, Phillips drive   | 12mm | 100 per pack | By Others    |
|  | <b>Screws for masonry framing</b> - for face fixing panels at soffit line and other locations where required onto Rondo H515 Top Hats. Cat5 ArmaGalv, self-drilling, CSK self-embedding head, Square drive. Also used for fixing panel to metal corner. | 45mm | 100 per pack | By Others    |

## 05

## COMPONENTS + ACCESSORIES





Note: Codes can change from time to time. Refer to the website for the current list of components prior to ordering.

| Accessories   | Description   | Size                                  | Quantity                       | Product Code       |
|---|---|---------------------------------------|--------------------------------|--------------------|
|    | <b>Fasteners</b> – to fix backing strip and other components to framing. <ul style="list-style-type: none"> <li>• For fixing to timber framing – galvanised clout, 40 x 1.6mm</li> <li>• For fixing to steel framing – button head screws, class 3, 6g x 40mm self-drilling, Phillips drive</li> <li>• For fixing to H515 Top Hat – button head screws 8g, self-drilling, Phillips drive, 12mm for fixing starter strip and clip</li> </ul> |                                       | By Others                      |                    |
|    | <b>Horizontal Base Starter Strip</b> – Steel profile used at the base to locate the first row of panels. Manufactured from 1.2mm BMT steel with Galvalume AZ150 corrosion resistant coating.  | 85mm x 15mm x 3000mm                  | 1 each                         | 487083             |
|    | <b>Horizontal Starter Strip</b> – steel profile used at the base to locate the first row of panels. Provides 15mm offset from face of studs. Manufactured from 1.2BMT steel with Galvalume AZ150 corrosion resistant coating.   | 3030mm                                | 1 each                         | 136823             |
|    | <b>Horizontal Panel Clip</b> – fixed to the framing to retain the tongue and groove edges of panels. Manufactured from SuperDyma corrosion resistant coated steel.  | 72mm x 45mm x 15mm                    | 50 per pack                    | 105364             |
|    | <b>Horizontal Panel Clip Flashing</b> – Used behind each Panel Clip. Galvalume AZ150 corrosion resistant coating.   | 70mm x 56mm                           | Pack of 200                    | 487047             |
|   | <b>Corner Clip</b> – fixed to the framing to retain the tongue and groove edges of the pre-formed external corner. Manufactured from SuperDyma corrosion resistant coated sheet.  | 45mm x 45mm x 15mm                    | 24 per pack                    | 153018             |
|  | <b>Corner Clip Flashing</b> – Used behind each Corner Clip. Galvalume AZ150 corrosion resistant coating.  | 45mm x 56mm                           | Pack of 100                    | 487048             |
|  | <b>50mm Horizontal Spacer</b> – for packing between framing and panels at eaves and other locations wherever face fixing is required. Manufactured in extruded plastic.   | 15mm x 50mm x 1200mm                  | 1 each                         | 111502             |
|  | <b>Steel Top Hat</b> – for framing on masonry substrate. Rondo H515. Manufactured from galvanised (Z275) 1.15mm BMT steel. Requires screws 8G, self-drilling, button head, Phillips drive 12mm for fixing starter strip and short [and long] clips to H515 Top Hat. Suitable for corrosion zones B & C only.  | 80mm x 15mm with 500mm face 0.91 kg/m | 1 each – 3.6m<br>1 each – 7.2m | Supplied by others |
|  | <b>Eaves Trim</b> – Provides an attractive finish at eaves junction and provides cavity ventilation. Powder coated finish on 1.0mm Aluminium.   | 60 x 26 x 3030mm                      | 1 each<br>White<br>Black       | 487265<br>487264   |
|  | <b>Eaves Trim External Corner</b> – provides joint at external eaves trim corner. Powder coated finish on 1.0mm Aluminium.  | 100mm x 100mm                         | Pack of 4<br>White<br>Black    | 192846<br>192844   |
|  | <b>Eaves Trim Internal Corner</b> – provides joint at internal eaves trim corner. Powder coated finish on 1.0mm Aluminium.  | 100mm x 100mm                         | Pack of 4<br>White<br>Black    | 192850<br>192848   |
|  | <b>Soffit Trim</b> – provides finish at soffit edge as well as cavity ventilation and cavity closure below battens. Powder coated finish on 0.35mm BMT steel with Galvalume AZ150 corrosion resistant coating.  | 3030mm                                | 1 each<br>White                | 134448             |
|  | <b>Soffit Trim External Corner</b> – provides joint at soffit trim corner. Powder coated finish on 0.35mm BMT steel with Galvalume AZ150 corrosion resistant coating.   |                                       | White                          | 134396             |
|  | <b>Soffit Trim Internal Corner</b> – provides joint at soffit trim corner. Powder coated finish on 0.35mm BMT steel with Galvalume AZ150 corrosion resistant coating.   | 135206                                | Pack of 2<br>White             | 134430             |



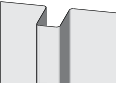

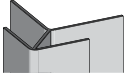
## COMPONENTS + ACCESSORIES

05

Note: Codes can change from time to time. Refer to the website for the current list of components prior to ordering.

|   |   |                            |                  |        |
|---|---|----------------------------|------------------|--------|
|    | <b>Joint Backing Strip Double Flange</b> – used at vertical joints to fill cavity and provide a backing for sealant. Manufactured in 0.3mm BMT steel with Galvalume AZ150 corrosion resistant and bond breaker coating. Forms 10mm wide express joint.  | 135208                     | 1 each           | 122804 |
|    | <b>Joint Backing Strip Single Flange</b> – used at vertical internal corner joints and at openings to fill cavity and provide a backing for sealant. Manufactured in 0.3mm BMT steel with Galvalume AZ150 corrosion resistant and bond breaker coating. | 135207                     | 1 each           | 111500 |
|    | <b>Internal Corner Flashing</b> – metal angle flashing used in some corners. Manufactured from steel with Galvalume AZ150 corrosion resistant coating.  | 50mm x<br>50mm x<br>2400mm | 1 each           | 487011 |
|    | <b>Cavity Closure</b> – UPVC profile used above windows, doors and similar openings as a vermin barrier.  | 50mm x 15mm<br>x 3000mm    | 1 each           | 487013 |
|    | <b>90mm Vertical Spacer</b> – for use with metal corners.   | 15mm x 90mm<br>x 2000mm    | 1 each           | 123595 |
|    | <b>External aluminium corner trim</b> – anodised aluminium extrusion used to dress and finish external corners.   | 60mm x<br>65mm x<br>3030mm | 1 each<br>Silver | 135041 |
|   | <b>L-Form Cavity Vent</b> – used at parapet and horizontal control joints to provide air flow while maintaining vermin proofing. Has self-adhesive EPDM tape for fixing into flashing/capping and compressible foam filler attached internally.         | 1200mm                     | 1 each           | 129750 |
|  | <b>Cemintel Edge Sealer</b> – for sealing panel edges after on-site cutting.  | 200ml                      | 1 each           | 100166 |
|  | <b>Territory Putty</b> – Putty required to patch exposed fixings on Smartfit Windows or fill holes in Territory panels.   | 330mL                      | 1 each           | 487263 |

## Tools

| Product   | Description   | Size        | Quantity | Product Code       |
|---|---|-------------|----------|--------------------|
|  | <b>Cemintel Power Saw Blade</b> – specifically designed for cutting pre-finished cement based sheets. Ideal for use with dustless circular saws fitted with vacuum extraction systems. 15000 RPM max. | 125mm       | 1        | 134449             |
|  | <b>Makita Plunge Saw Kit (1300W) includes 1400mm guide rail and bonus 165mm fibre cement saw blade</b> – excellent for cutting cement based sheets  | 165mm       | 1        | Supplied by others |
|  | <b>Makita 165mm Fibre Cement Saw Blade</b> – ideal for use with the Makita Plunge saw and other 165mm circular saws fitted with vacuum extraction systems   | 165mmx20x4T | 1        | Supplied by others |
|  | <b>FESTOOL DSC-AGP 125</b> – Diamond Blade Cutting and Grinding Tool. Used to provide neat and accurate bevelled edges  | 125mm       | 1        | Supplied by others |
|  | <b>FESTOOL TS 55 EBQ Plunge Cut Saw</b> – with 1400mm Guide Rail. Precise plunge cuts in materials up to 55mm thick.  | 160mm       | 1        | Supplied by others |
|   | <b>FESTOOL Diamond Tipped Blade for TS 55</b> – for cutting all fibre cement sheet products   | 160mm       | 1        | Supplied by others |



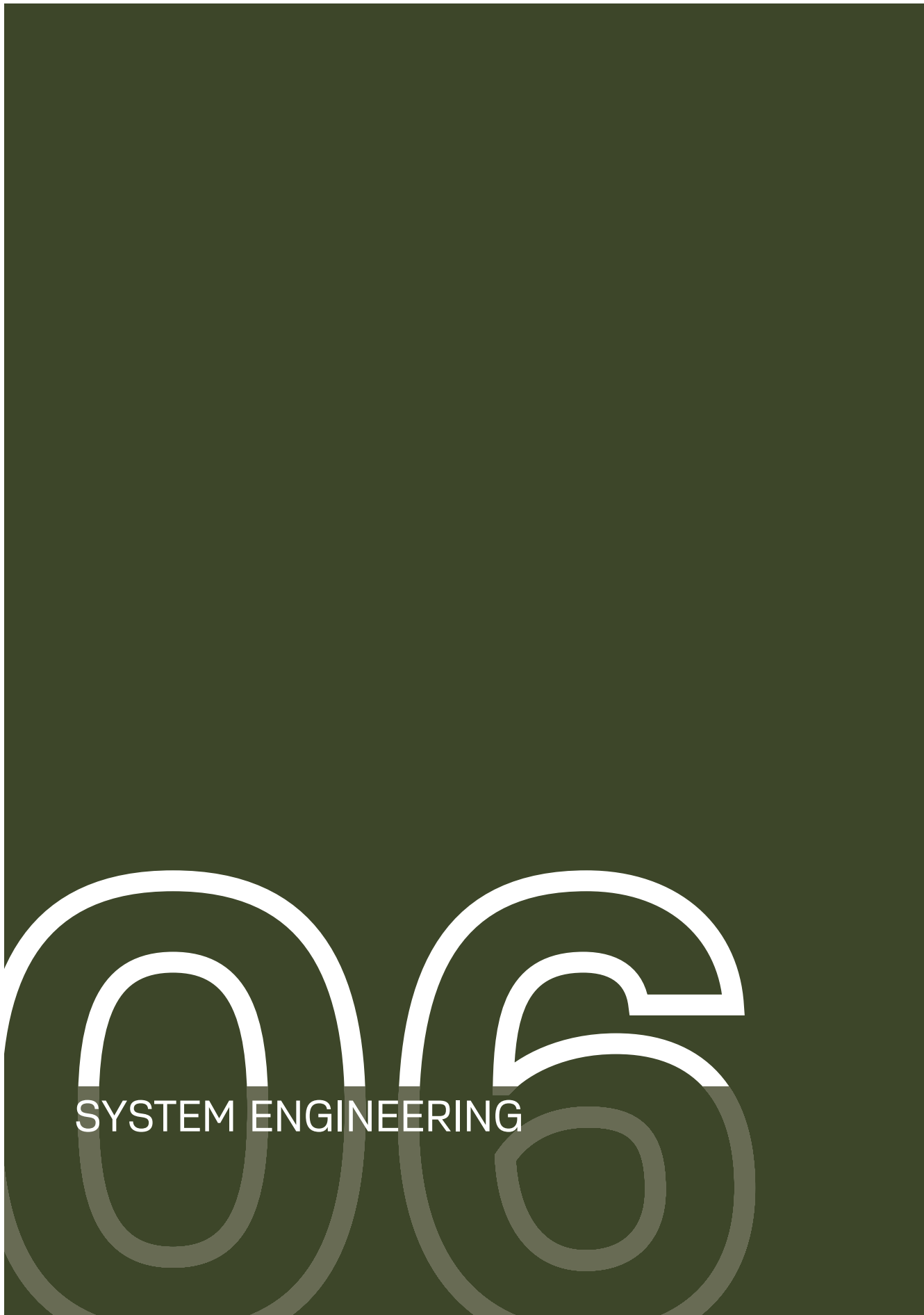

SYSTEM ENGINEERING



## Design, Detailing And Performance Responsibilities

Cemintel engages independent testing laboratories to test and report on the performance of a wall in accordance with the relevant New Zealand Standards. Consultants use these reports as the basis for opinions (estimates of laboratory performance) they issue for variations to the tested system. Using their experience, the consultant will make judgments about on-site installed performance of various walls. The performance levels of walls documented in this guide are either what is reported in a test or the documented opinion of consultants. Performance in projects is typically the responsibility of:

### **Project Consultants (Structural, Fire, Acoustic, Etc.)**

These consultants are typically responsible for the following:

- Opinions on expected laboratory performance of wall configurations that vary from actual test configuration, such as substitution products and components.
- Judgements about expected field performance using laboratory test reports and practical experience.
- Design, specification and certification of structural, fire, acoustic, durability, weather tightness and any other required performance criteria for individual projects.

This involves the design and selection of building elements, such as wall and floors and their integration into the building considering the following:

- Interface of different building elements and to the structure / substrate.
- Wall and floor junctions.
- Penetrations.
- Flashing design.
- Room / building geometry.
- Acoustic and water penetration field-testing.

### **Project Certifier and/or Builder**

These professionals are typically responsible for:

- Identifying the performance requirements for the project in accordance with the NZBC and clearly communicating this to the relevant parties.
- Applicability of any performance characteristics supplied by Cemintel NZ including test and opinions for the project.
- The project consultant's responsibilities detailed above if they are not appointed.

Cemintel NZ, does not provide consulting services. Cemintel NZ, only provides information that has been prepared by others and therefore shall not be considered experts in the field.

Any party using the information contained in this guide or supplied by Cemintel NZ in the course of a project must satisfy themselves that it is true, current and appropriate for the application, consequently accepting responsibility for its use.

It is the responsibility of the architectural designer and engineering parties to ensure that the details in this design guide are appropriate for the intended application.

The recommendations in this guide are formulated along the lines of good building practice, but are not intended to be an exhaustive statement of all relevant data.

Cemintel NZ is not responsible for the performance of constructed walls, including field performance, and does not interpret or make judgements about performance requirements in the NZBC.



## SYSTEM ENGINEERING

### Span Tables / Wind Loads

**TABLE 6.01** Fixing Requirements for Timber Framing – Based on Wind Category

| Wind Category | Maximum Stud Spacing                        |  |
|---------------|---|--|
|               | CORNER ZONES<br>Minimum Fixing Requirements | GENERAL ZONES<br>Minimum Fixing Requirements |
| Low           | 600mm cts                                   | 600mm cts                                    |
| Medium        | 600mm cts                                   | 600mm cts                                    |
| High          | 600mm cts                                   | 600mm cts                                    |
| Very High     | 600mm cts                                   | 600mm cts                                    |
| Extra High    | 600mm cts                                   | 600mm cts                                    |

NOTE: Table based on external pressures only, with internal linings designed to resist internal pressures. Approved fasteners must be used. General Zone: Areas greater than 1200mm from an external building corner. Corner Zone: Areas less than 1200mm from an external building corner.

**TABLE 6.02** Fixing Requirements for Timber Framing – Based on Wind Pressures

| Designed Wind Pressure<br>(Ultimate)<br>(kPa) | Minimum Fixing Requirements |
|---|-----------------------------|
| 0 - 2.5                                       | 600mm cts                   |
| 2.5 - 3.4                                     | 450mm cts                   |
| 3.4 - 5.0                                     | 300mm cts                   |

Note: Design wind pressures apply to both negative and positive pressures.

**TABLE 6.03** Fixing Requirements for Steel Framing - Based on Wind Category – Studs at 600mm max. centres

| Wind Category | PANEL ZONE – Minimum Fixing Requirements for areas greater than 1200mm from an External Building Corner |                |                |
|---------------|---|----------------|----------------|
|               | Steel Frame Metal Thickness   |                |                |
|               | 0.5mm   | 0.75mm         | 1.2mm          |
| Low           | Clip @ 600 cts  | Clip @ 600 cts | Clip @ 600 cts |
| Medium        | Clip @ 600 cts  | Clip @ 600 cts | Clip @ 600 cts |
| High          | Clip @ 600 cts  | Clip @ 600 cts | Clip @ 600 cts |
| Very High     | Clip @ 600 cts  | Clip @ 600 cts | Clip @ 600 cts |
| Extra High    | Clip @ 600 cts + 1 Face Screw   | Clip @ 600 cts | Clip @ 600 cts |

| Wind Category | CORNER ZONE – Minimum Fixing Requirements for areas greater than 1200mm from an External Building Corner |                               |                |
|---------------|--|-------------------------------|----------------|
|               | Steel Frame Metal Thickness  |                               |                |
|               | 0.5mm  | 0.75mm                        | 1.2mm          |
| Low           | Clip @ 600 cts   | Clip @ 600 cts                | Clip @ 600 cts |
| Medium        | Clip @ 600 cts   | Clip @ 600 cts                | Clip @ 600 cts |
| High          | Clip @ 600 cts + 1 Face Screw  | Clip @ 600 cts                | Clip @ 600 cts |
| Very High     | Clip @ 600 cts + 1 Face Screw  | Clip @ 600 cts                | Clip @ 600 cts |
| Extra High    | Clip @ 600 cts + 1 Face Screw  | Clip @ 600 cts + 1 Face Screw | Clip @ 600 cts |

Note: System performance relies on the use of approved fasteners.

Table based on external pressures only, with internal linings designed to resist internal pressures. Where face fixing is required, fasteners are to be placed at the same spacings as indicated for clips.

## SYSTEM ENGINEERING

**TABLE 6.04** Fixing Requirements for Steel Framing - Based on Wind Pressures

| Design Wind Pressure (Ultimate) (kPa) | Minimum Fixing and stud Spacing Requirements |                               |                               |
|---------------------------------------|--|-------------------------------|-------------------------------|
|                                       | Steel Frame Metal Thickness (BMT)            |                               |                               |
|                                       | 0.5mm  | 0.75mm                        | 1.2mm                         |
| 1                                     | Clip @ 600 cts                               | Clip @ 600 cts                | Clip @ 600 cts                |
| 1.5                                   | Clip @ 600 cts + 1 Face Screw                | Clip @ 600 cts                | Clip @ 600 cts                |
| 2                                     | Clip @ 600 cts + 1 Face Screw                | Clip @ 600 cts                | Clip @ 600 cts                |
| 2.5                                   | Clip @ 450 cts + 1 Face Screw                | Clip @ 600 cts + 1 Face Screw | Clip @ 600 cts                |
| 3                                     | Clip @ 450 cts + 1 Face Screw                | Clip @ 600 cts + 1 Face Screw | Clip @ 600 cts + 1 Face Screw |
| 3.5                                   | Clip @ 300 cts + 1 Face Screw                | Clip @ 600 cts + 1 Face Screw | Clip @ 600 cts + 1 Face Screw |
| 4                                     | Clip @ 300 cts + 1 Face Screw                | Clip @ 450 cts + 1 Face Screw | Clip @ 600 cts + 1 Face Screw |
| 4.5                                   | Clip @ 300 cts + 1 Face Screw                | Clip @ 450 cts + 1 Face Screw | Clip @ 600 cts + 1 Face Screw |
| 5                                     | N/A  | Clip @ 450 cts + 1 Face Screw | Clip @ 600 cts + 1 Face Screw |
| 5.5                                   | N/A  | Clip @ 300 cts + 1 Face Screw | Clip @ 600 cts + 1 Face Screw |
| 6                                     | N/A  | Clip @ 300 cts + 1 Face Screw | Clip @ 600 cts + 1 Face Screw |

Note: Contact Cemintel NZ for projects outside of the scope of NZS3604 to confirm suitability.

**TABLE 6.05** Fixing Requirements for Steel Framing Without Face Fixing - Based on Wind Pressures

| Design Wind Pressure (Ultimate) (kPa) | Minimum Fixing and stud Spacing Requirements |                |                |
|---------------------------------------|--|----------------|----------------|
|                                       | Steel Frame Metal Thickness (BMT)            |                |                |
|                                       | 0.5mm  | 0.75mm         | 1.2mm          |
| 1                                     | Clip @ 600 cts                               | Clip @ 600 cts | Clip @ 600 cts |
| 1.5                                   | Clip @ 450 cts                               | Clip @ 600 cts | Clip @ 600 cts |
| 2                                     | Clip @ 300 cts                               | Clip @ 600 cts | Clip @ 600 cts |
| 2.5                                   | N/A  | Clip @ 450 cts | Clip @ 600 cts |
| 3                                     | N/A  | Clip @ 300 cts | Clip @ 450 cts |
| 3.5                                   | N/A  | Clip @ 300 cts | Clip @ 300 cts |
| 4                                     | N/A  | Clip @ 300 cts | Clip @ 300 cts |
| 4.5                                   | N/A  | N/A            | Clip @ 300 cts |
| 5                                     | N/A  | N/A            | Clip @ 300 cts |

Note: Contact Cemintel NZ for projects outside of the scope of NZS3604 to confirm suitability.



## SYSTEM ENGINEERING

### Masonry Substrates

Masonry wall must be structural and constructed from brick, concrete or concrete block in accordance with the relevant building codes. It is important the wall is plumb and true. Note the H515 Top Hat has limited ability for variations across the plane of the surface. Masonry fasteners must be designed by the project engineer.

**TABLE 6.06** Fixing Requirements for Masonry – Based on Wind Category

| Wind Category | Maximum Top Hat Spacing                    |   |
|---------------|--|---|
|               | CORNER ZONE<br>Minimum Fixing Requirements | GENERAL ZONE<br>Minimum Fixing Requirements |
| Low           | 600mm cts                                  | 600mm cts                                   |
| Medium        | 600mm cts                                  | 600mm cts                                   |
| High          | 600mm cts                                  | 600mm cts                                   |
| Very High     | 600mm cts                                  | 600mm cts                                   |
| Extra High    | 600mm cts                                  | 600mm cts                                   |

NOTE: Table based on external pressures only. Approved fasteners must be used. General Zone: Areas greater than 1200mm from an external building corner. Corner Zone: Areas less than 1200mm from an external building corner.

**TABLE 6.07** Fixing Requirements for Masonry Without Face Fixing – Based on Wind Pressure

| Design Wind Pressure (Ultimate) (kPa) | Minimum Fixing Requirements (Top Hats & Clip) |
|---------------------------------------|---|
| 1                                     | Clip @ 600mm cts                              |
| 1.5                                   | Clip @ 600mm cts                              |
| 2                                     | Clip @ 600mm cts                              |
| 2.5                                   | Clip @ 600mm cts                              |
| 3                                     | Clip @ 300mm cts                              |
| 3.5                                   | Clip @ 300mm cts                              |
| 4                                     | Clip @ 300mm cts                              |
| 4.5                                   | Clip @ 300mm cts                              |
| 5                                     | Clip @ 300mm cts                              |

NOTE: Contact Cemintel NZ for projects outside of the scope of NZS3604 to confirm suitability.

**TABLE 6.08** Fixing Requirements for Masonry – Based on Wind Pressure

| Design Wind Pressure (Ultimate) (kPa) | Minimum Fixing Requirements (Top Hats & Clip) |
|---------------------------------------|---|
| 1                                     | Clip @ 600mm cts                              |
| 1.5                                   | Clip @ 600mm cts                              |
| 2                                     | Clip @ 600mm cts                              |
| 2.5                                   | Clip @ 600mm cts                              |
| 3                                     | Clip @ 600 cts + 1 Face Screw                 |
| 3.5                                   | Clip @ 600 cts + 1 Face Screw                 |
| 4                                     | Clip @ 600 cts + 1 Face Screw                 |
| 4.5                                   | Clip @ 600 cts + 1 Face Screw                 |
| 5                                     | Clip @ 600 cts + 1 Face Screw                 |
| 5.5                                   | Clip @ 600 cts + 1 Face Screw                 |
| 6                                     | Clip @ 600 cts + 1 Face Screw                 |

NOTE: Contact Cemintel NZ for projects outside of the scope of NZS3604 to confirm suitability.



# 07

INSTALLATION

## CHECKLIST – Prior to Installation

The following pre-install checklist may assist to ensure you have the best possible outcome when using Cemintel Territory.



Check quality and quantity of panels and components before installing. If there is any sign of damage or visible defects in panels, or the colour/finish is not in keeping with the owners aesthetic requirements DO NOT INSTALL. Contact Cemintel to address any issues.

- Ensure substrate is straight and plumb. Pack studs to straighten if necessary (timber frames as per NZS3604, steel frames as per NZS3404 or AS/NZS 4600 industry best practice for frame tolerance is 5mm misalignment over 3000mm.
- Ensure studs are correctly located and of the appropriate thickness.
- Confirm bracing is in place. Where sheet bracing is used behind panels, the entire wall area needs to be braced or bracing sheet packers fixed to the frame to ensure a uniform fixing plane.
- Remove any concrete that may foul the cladding line, particularly at steps in slabs and isolated columns.
- Ensure there is adequate ground clearance to the bottom edge of the Territory panels as per regulatory requirements.
- Confirm your panel layout to determine the location of joints and identify where additional studs are required at all short edge joints and internal and external corners.
  - If using pre-formed corners, studs need to be located to allow fastening of corner clips to support the corners.
  - Additional studs or blocking may be required for support and fixing of Territory joint backing strips at corners and junctions.
  - To allow for replacement of panels, a vertical break is recommended every 7 metres.
- Flashings, membranes and air barrier should be correctly installed, overlapped and taped at joints, prior to fixing panels. In the case of fixing to masonry, the top hats should be installed correctly. (Wall wrap is not required when installing over masonry.)
- Install windows so that the back of the front face of the window (or any other protrusions including doors or meter boxes) will be flush with the face of the panels.
- Where there is no space to use a mounting clip along the bottom and top edge of the window, tack a horizontal green spacer to provide a firm surface for the cladding panel to maintain its position.
- Fit Head flashings over windows, doors and other penetrations.
- Confirm the chosen eaves/soffit details and prepare accordingly.
- Consider the need for structural support for fixtures such as pergolas and decking. No loads may be carried by the cladding.
- Confirm membranes and flashings for deck areas have been installed in accordance with manufacturers' specifications.
- Arrange for a pre-cladding inspection by the appropriate local building authority if required.



### Installation Set-Out

#### Timber Framing

**Timber framing must be in accordance with NZS3604 – Residential Timber-Framed Construction.**

Standard framing techniques are appropriate for the horizontal panel system with the addition of double studs at all vertical panel joints to allow for fixing clips each side of the panel joint.

**FIGURE 7.01** Typical Framing Set-Out with 90mm Timber Framing and Territory Pre-formed Corners – Plan View

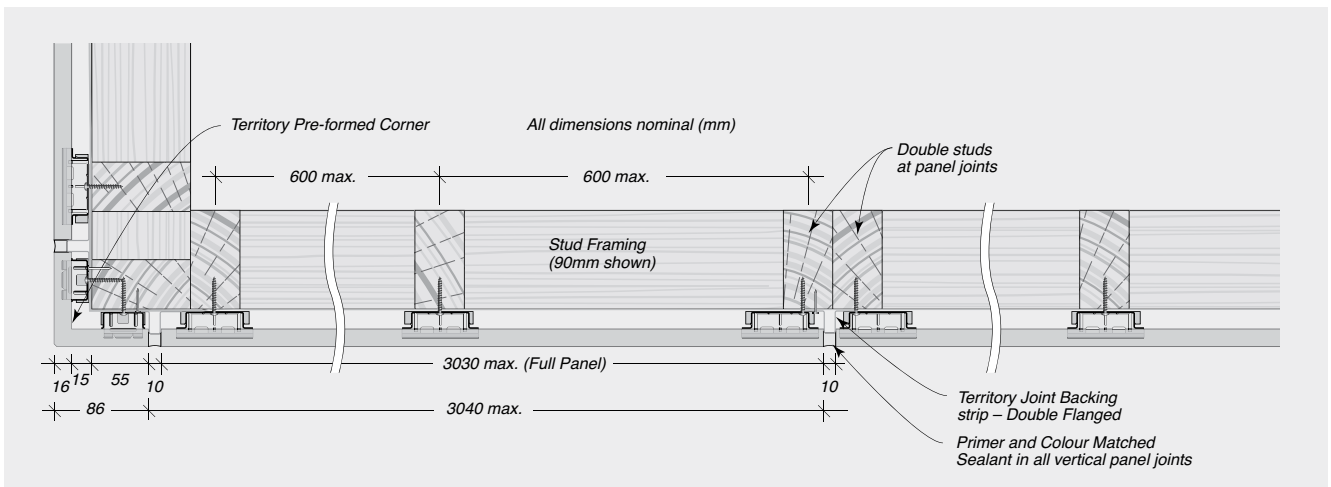

**FIGURE 7.02** Typical Framing Set-Out with 70mm Timber Framing and Territory Pre-formed Corners – Plan View

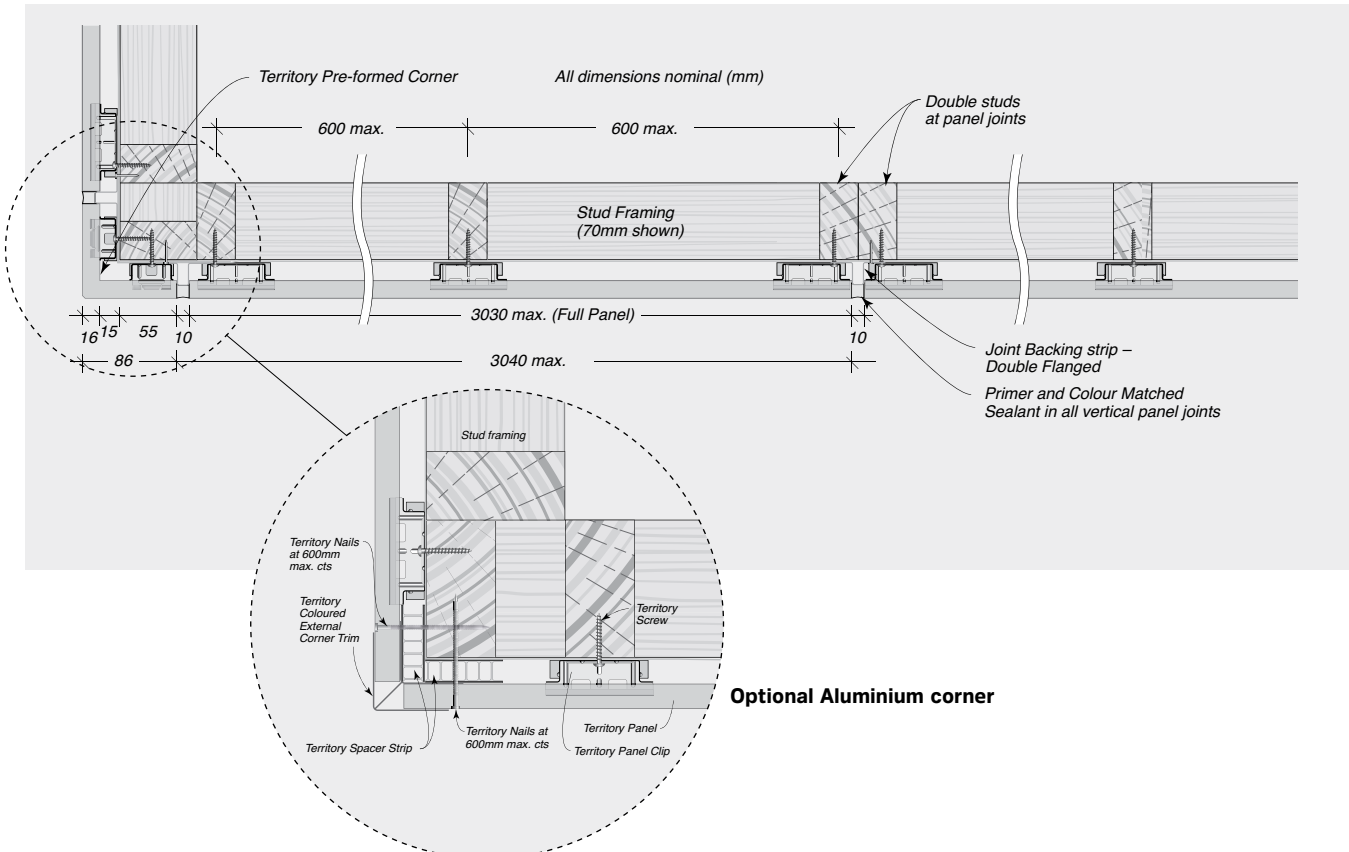

07

INSTALLATION

**FIGURE 7.03** Typical Territory System Cross Section for Timber Framing - Elevation

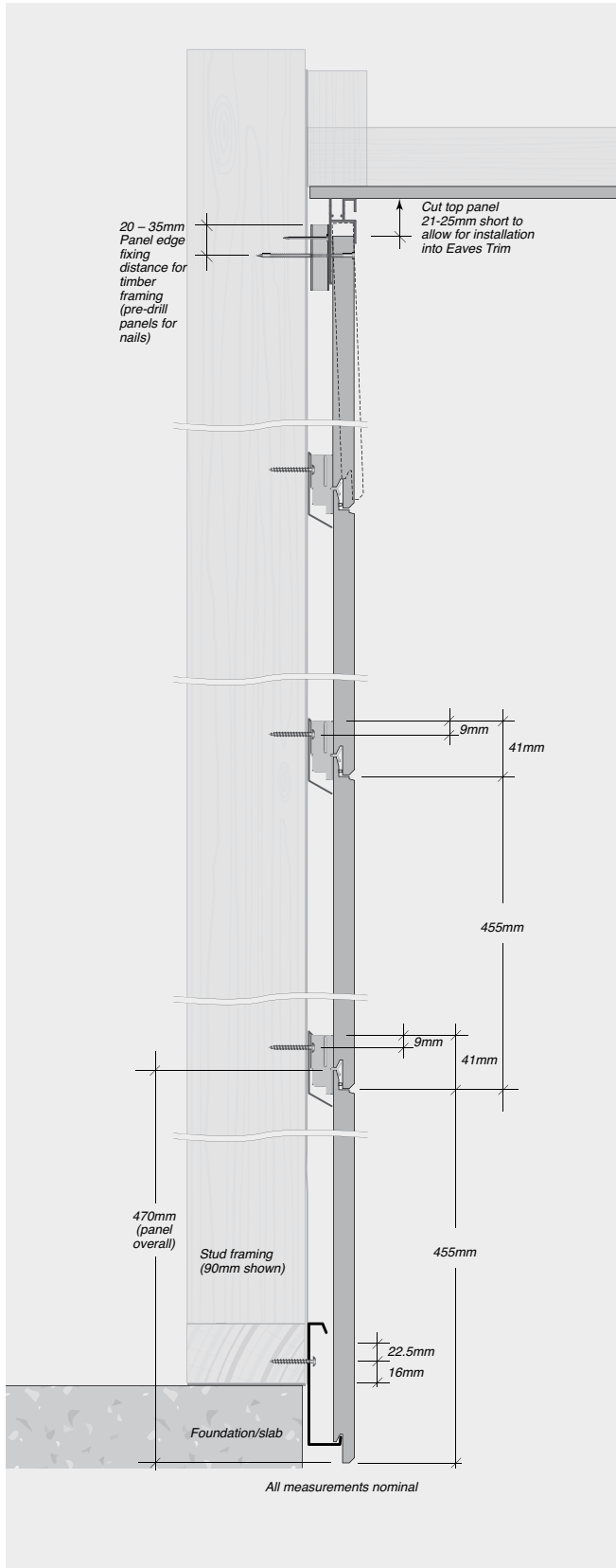

**FIGURE 7.04** Typical Territory System Cross Section for Timber Framing for when face fixing is required - Elevation

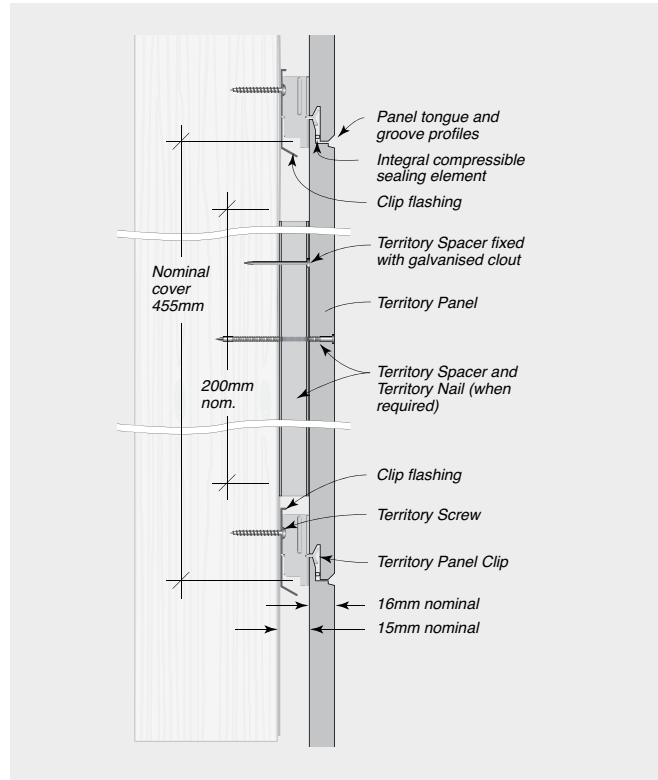

Steel Framing

Steel framing must be in accordance with AS/NZ4600 or NZS 3404.

FIGURE 7.05 Typical Framing Set-Out with 90mm Steel Framing and Territory Pre-formed Corners - Plan View

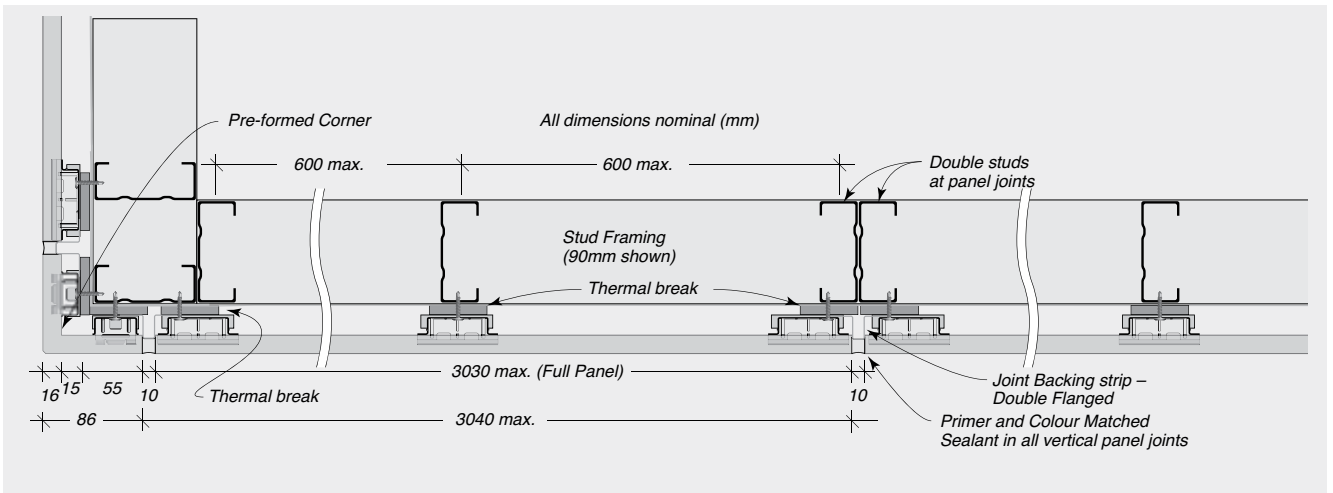
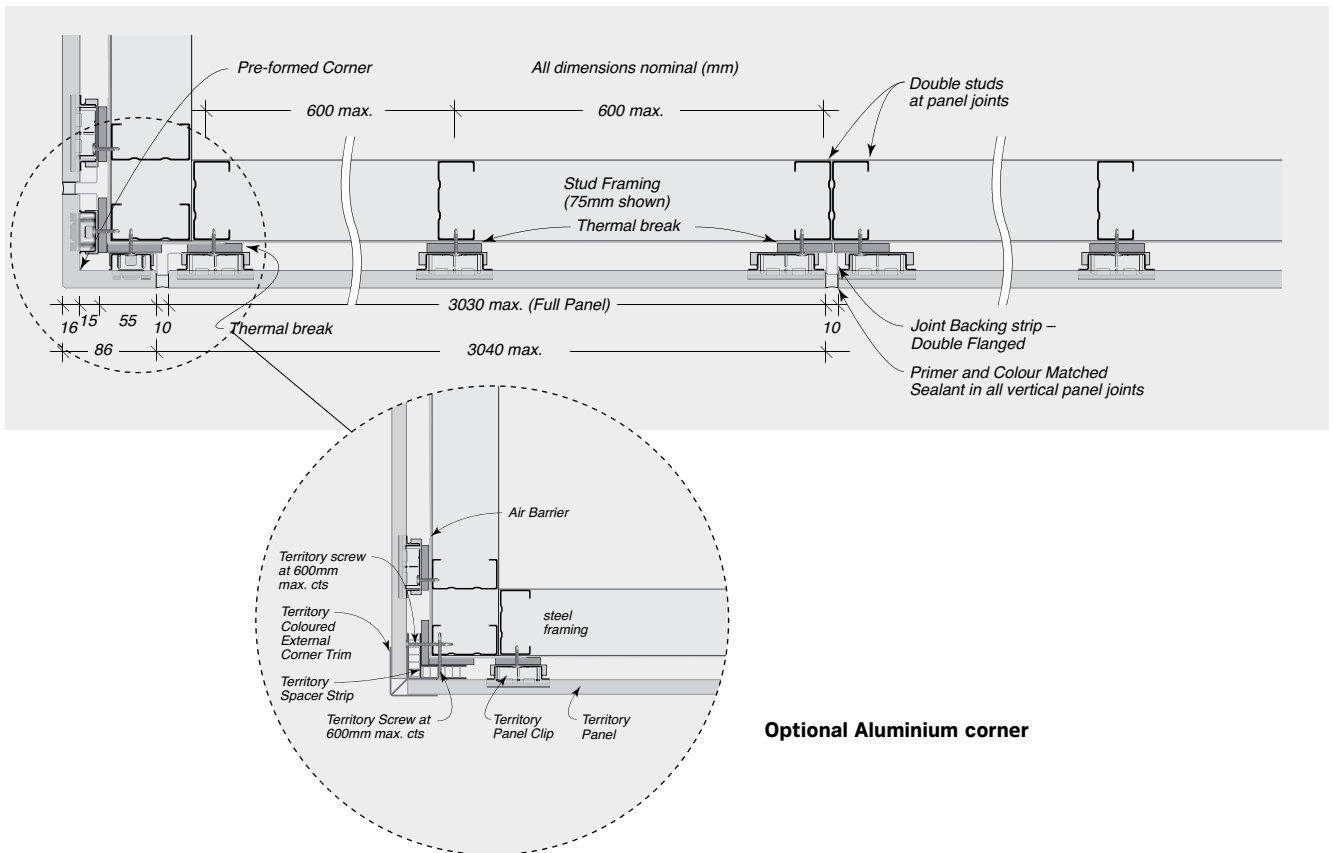

FIGURE 7.06 Typical Framing Set-Out with 75mm Steel Framing and Territory Pre-formed Corners - Plan View



07

INSTALLATION

**FIGURE 7.07** Typical Territory System Cross Section for Steel Framing - Elevation

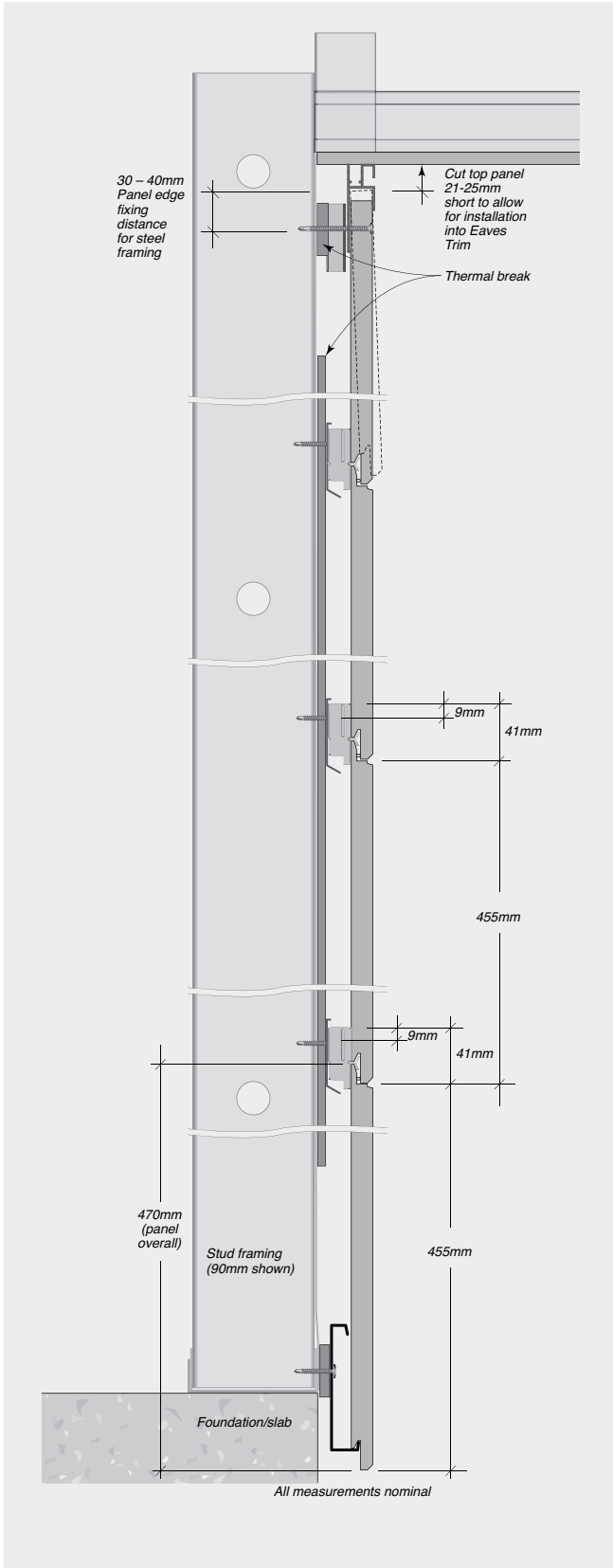

**FIGURE 7.08** Typical Territory System Cross Sectional Detail for Steel Framing where Face Fixing is required - Elevation

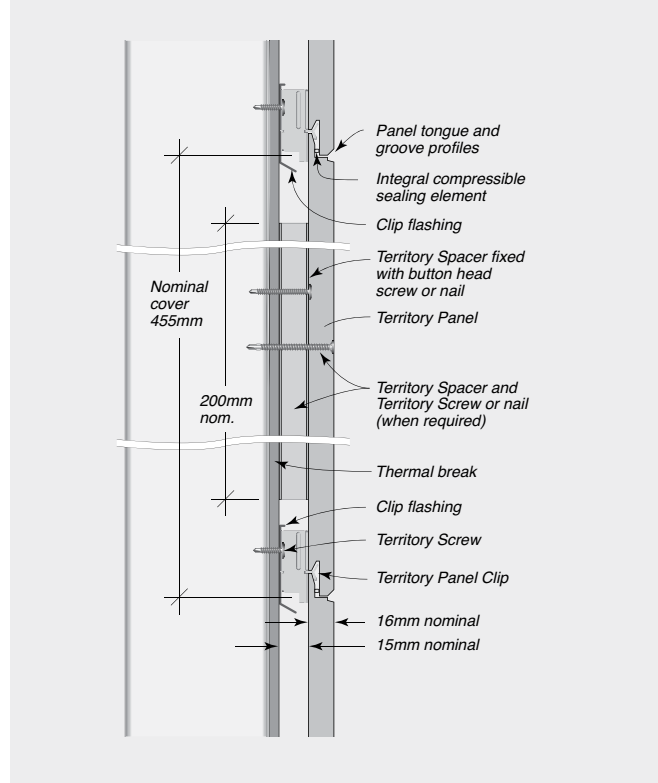

## Masonry Framing

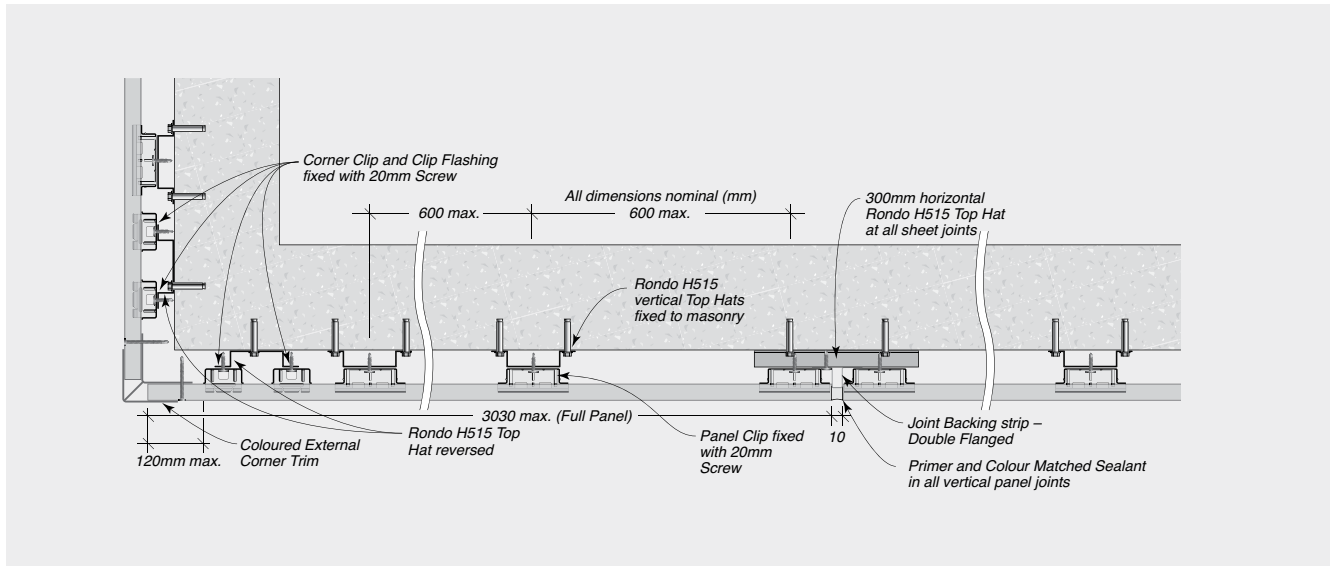
**FIGURE 7.09** Typical Set-Out with H515 Top Hat Framing and Territory Aluminium Corners - Plan View



Masonry Framing

**FIGURE 7.10** Typical Masonry Territory System Cross Section - Elevation

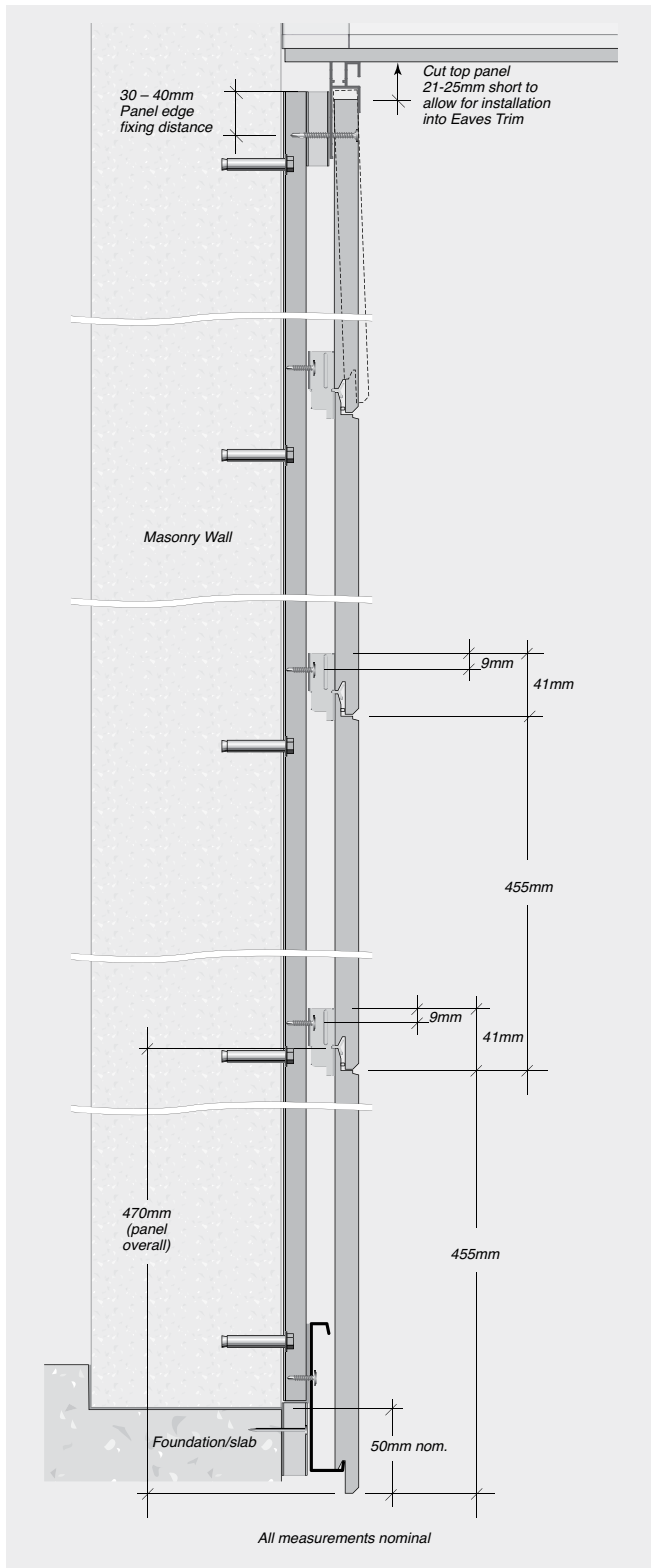

**FIGURE 7.11** Typical Territory System Cross Sectional Detail for Masonry substrate where face fixing is required - Elevation

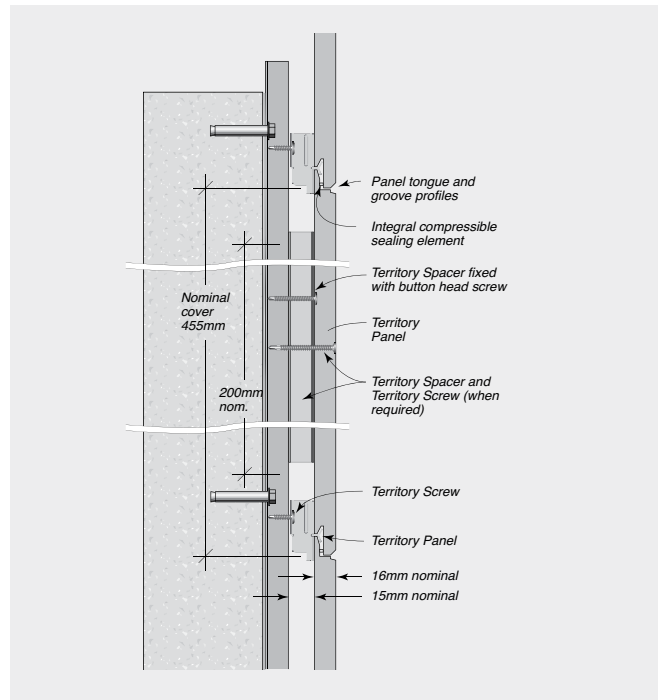

INSTALLATION



FIGURE 7.12 Masonry Overview Detail

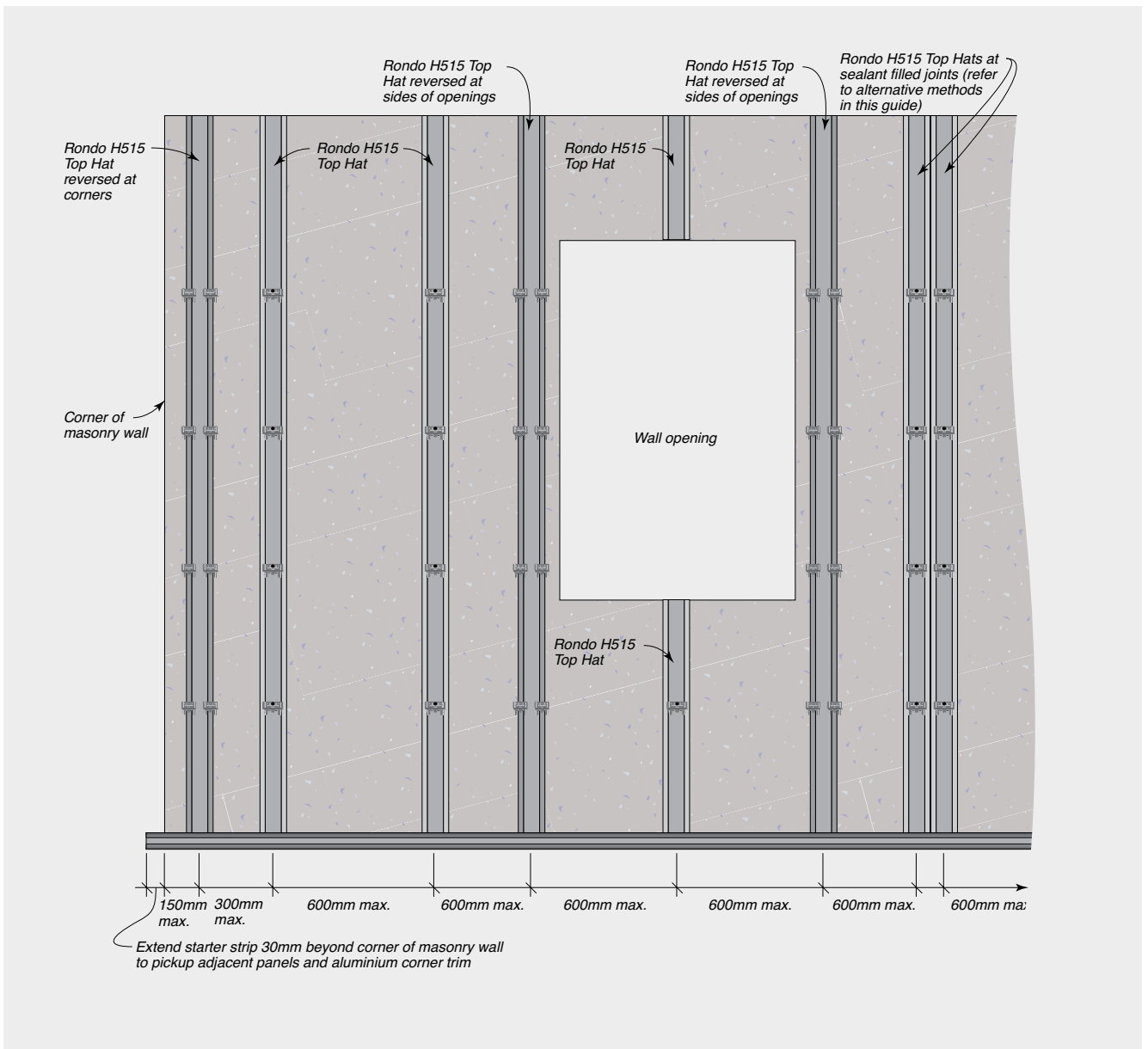

## Installation for Timber and Steel Framing

Refer to 'System Engineering' and 'Construction Drawings and Details' sections for specific fixing information.

**Step 1 – Install horizontal base starter strip** to the base of the wall. The panel will overhang 16mm from the bottom of the base starter strip when it sits on the starter strip, and the first row of panels needs to be positioned to end 50mm below the base of the bottom plate.

Fasten the starter strip level along the whole length of the strip to the bottom plate. Because each panel sits on top of the other, any errors in setting the level on the first wall panel will be compounded through each layer. It is therefore critical to ensure the starter strip is fitted level, ready to accept the first panel.

### Step 2 – Install joint backing strips

Install joint backing strips at all vertical joint locations.

### Step 3 – Install corners

- A.** If installing prefinished corners, slide the first corner piece down the corner and over the starter strip. Then insert the narrow corner clip on each side and screw to the stud. It is important to ensure that each corner piece is square on both sides. If the corners are not square, pack out the clips. To add the next corner piece, slide it on top so that it sits firmly on the clips and tap into position. Secure another set of clips to the top of the corner and screw fix to framing.
- B.** If installing aluminium corners, cut to length remembering to deduct the height measurement of the eaves trim. Notch out to extend over the starter strip. To maintain the 15mm cavity, first tack spacers on each side of the corner stud. Allow a small amount of space at the top to allow for ventilation. Fix the eaves corner piece. Then, ensuring the aluminium corner trim is level, nail or screw it through the spacer to the frame. The wall panel should fit into the corner trim channel and slide down onto the starter strip.

**Step 4 – Install wall panels.** When cutting panels it is important that any cut edges are sealed with Cemintel's recommended edge sealant to protect against moisture entering the panels.

Place the first wall panel over the starter bar and slide into place. Position horizontal panel clips firmly over panels at every stud and screw into place. Pack out the clips if necessary to ensure a uniform fixing plane. We recommend consulting the local building surveyor regarding appropriate materials for packing.

Where face fixing may be required, a strip of Spacer (cut to a minimum length of 200mm) should be positioned between the panel and the frame, thus maintaining the 15mm cavity.

**Step 5 – Finishing at the soffit.** Fix a strip of spacer (or cut to a minimum length of 200mm at each stud) below the eaves or soffit to maintain the 15 mm cavity.

Slide the eaves trim into the eaves corner piece. Install the eaves trim hard against the eaves or soffit and fix through the spacer onto each stud. In the case of a backing strip being located on a stud, notch the back of the eaves trim so as to fit over the backing strip.

Cut the top panel/prefinished corner 5-10mm shorter than the height inside of the eaves trim to allow lifting of the final panel and dropping into place. Mark the position of the studs to identify fastening points. Predrill panels. Fasteners should be located 20-35mm from panel edges for timber frames or 30-40mm for steel frames.

Tilt the panel out at the bottom and insert the top edge of the panel into the eaves trim. Lift panel up and locate the bottom edge of the panel onto the clips already installed. Once firmly in place, nail panels to the studs using the Cemintel supplied face fix nails.

**Step 6 – Seal all expansion joints.** Apply masking tape to each side of the vertical joints and at the base. Paint the edges of the panels with the primer. This helps the sealant adhere to the panels. Wait at least 30 minutes but no more than 6 hours to apply the sealant. Smooth off the finish removing excess sealant. Carefully remove masking tape in accordance with manufacturer's instructions. CARE NEEDS TO BE TAKEN NOT TO GET SEALANT ON PANELS as this can result in marks and stains.

Install sealant to gaps at windows and other penetrations.

### Step 7 - Touch up any exposed fasteners.

Wipe panels down with a damp cloth and touch up any exposed nail or screw heads with matching touch up paint.

## INSTALLATION

07

- 1 Install building wrap. 2 Install Starter Strip and screw fix at 250mm max. centres. 3 Install Joint Backing Strip at joint location. 4 Install Preformed Corner and firmly tap corner onto the starter strip. 5 Install Corner Clips with Clip Flashing, firmly tap into place and screw fix to framing. 6 Adjust joint backing strip and fix to framing. 7 Install Panel and firmly tap into place. 8 Install Panel Clips with Clip Flashing, firmly tap into place and fastener fix to framing. Repeat step 1 to step 8 for adjacent panels and rows.

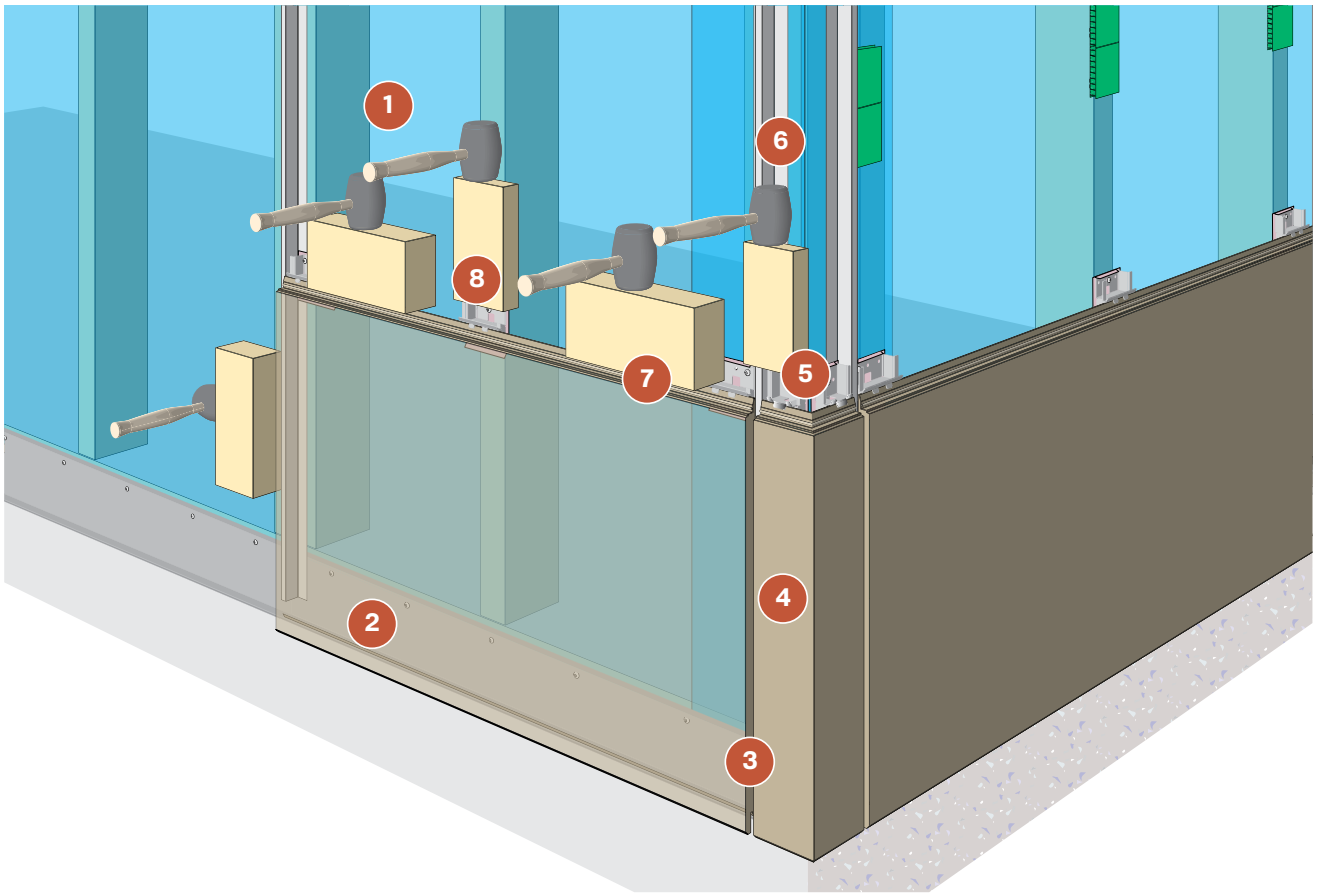

- 9 Fastener fix Spacer Strip on each stud. (If additional face fixing is required, install 50mm sections of spacer strip at fixing locations). 10 Install Eaves Trim hard against eaves sheet and fix through spacer with fastener at each stud. Notch the back of the eaves trim to allow for the Joint Backing Strip. 11 Tilt Panel out at the bottom, insert top into Eaves Trim, lift panel up and locate bottom of panel onto Clips. 12 Pre-drill holes through panels for nails. 13 Face fix panel with fastener through Eaves Trim at each stud and 20-35mm from panel edges.

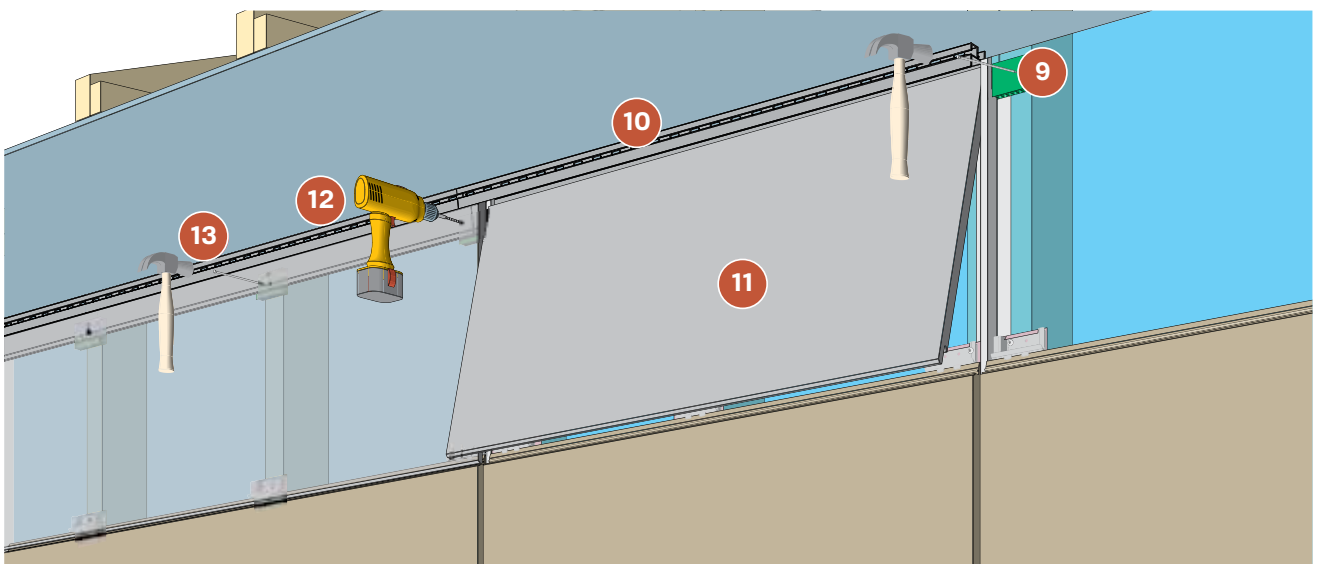

## Installation for Masonry

Refer to 'System Engineering' and 'Construction Drawings and Details' sections for specific fixing information.

Note that masonry structures are potentially more likely to be out of plumb. The Top Hat installation detailed in this Guide only allows for a small variation in the surface plane and industry best practice for frame tolerances of 5mm misalignment over 3000mm should be followed. Careful assessment should be undertaken to determine if this solution is appropriate for the specific situation.

Metal corners are recommended when installing onto masonry.

**Step 1 – Install H515 Top Hats** vertically at maximum 600mm centres. To account for minimum edge distance of masonry fixings, install Top Hats in reverse at corners and openings.

**Step 2 – Install the starter strip** to the base of the wall, screw fixing at each Top Hat. Make allowance for 16mm panel overhang. Ensure 10-15mm clearance between base flashing and bottom edge of panel. Starter strip needs to be extended 30mm beyond the end of the wall to accommodate the cavity (H515 and clips).

**Step 3 – Install joint backing strips.** Install joint backing strips at all vertical joint locations.

**Step 4 – Install wall panels.** Cut panel as required and seal any cut edges with Cemintel edge sealer. Install first panel, firmly tapping panel onto the starter strip. Check level and ensure a uniform fixing plane. Install panel clips to the edge of the panel, firmly tap into place and screw fix at each H515 Top Hat.

Where face fixing may be required, a strip of Spacer (cut to a minimum length of 200mm) is to be positioned between the panel and the Top Hat frame, thus maintaining the 15mm ventilated cavity.

Fasteners should be located 30-40mm from panel edge.

Repeat the above steps for additional rows of panels.

**Step 5 – Finishing at the soffit.** Fastener fix a strip of spacer on each H515 Top Hat below the Eave or Soffit to maintain the 15mm cavity. Slide the eaves trim into the eaves corner piece. Install the eaves trim hard against eave or soffit and fix through the spacer at each H515 Top Hat. In the case of a backing strip, notch the back of the Eave Trim so as to fit over the backing strip.

Cut the top panel/prefinished corner 5-10mm shorter than the height inside of the eaves trim to allow lifting of the final panel and dropping into place. Tilt the panel out at the bottom and insert the top edge of the panel into the eave trim. Lift panel up and locate the bottom edge of the panel onto the clips already installed. Once firmly in place, face fix the top of the panel with fasteners through the spacer strips at each Top Hat, 30-40mm from panel edges.

**Step 6 – Install metal external corners.** Once panels are installed along one wall, slide aluminium corner into position and fix using 45mm screw. Proceed to install panels along adjacent wall. Note that when cutting corners to length remember to deduct the height measurement of the eave trim.

**Step 7 – Seal all expansion joints.** Apply masking tape to each side of the vertical joints and at the base. Paint the edges of the panels with the primer. This helps the sealant adhere to the panels. Wait at least 30 minutes but no more than 6 hours to apply the colour matched sealant. Smooth off the finish removing excess sealant. Carefully remove masking tape in accordance with manufacturer's instructions. CARE NEEDS TO BE TAKEN NOT TO GET SEALANT ON PANELS as this can result in marks and stains. Install sealant to gaps at windows and other penetrations.

**Step 8 – Touch up any exposed fasteners.** Apply a metal primer and touch up paint to all visible fastener heads.



CONSTRUCTION  
DRAWINGS + DETAILS



## CONSTRUCTION DRAWINGS AND DETAILS

Note: Drawings are interchangeable for timber or steel substrates with the exception of the fasteners.

### Drawings Index

| SECTION                                  | DESCRIPTION   | FIGURE REFERENCE | PAGE NUMBER |
|--|---|------------------|-------------|
| <b>Base Details</b>                      | Base Detail – 90mm Framing  | 8.01             | 39          |
|  | Base Detail – 70mm Framing  | 8.02             | 39          |
|  | Alternate Base Fixing Detail  | 8.03             | 39          |
| <b>Soffit Details</b>                    | Soffit Detail – With Coloured Eaves Trim – Elevation                                    | 8.04             | 40          |
|  | Alternative Soffit Detail – With Timber Trim – Elevation                                | 8.05             | 40          |
|  | Soffit Detail   | 8.06             | 40          |
|  | Soffit Detail - With Soffit Trim – Elevation  | 8.07             | 40          |
| <b>Corner Details</b>                    | External Corner Detail – With Preformed Corner – Plan View                              | 8.08             | 41          |
|  | External Corner Detail – With Coloured External Corner Trim – Plan View                 | 8.09             | 41          |
|  | Internal Corner Detail – With Backing Strip and Colour Matched Sealant – Plan View      | 8.10             | 41          |
|  | Obtuse Angle Corner Detail – With Metal Flashing and Colour Matched Sealant – Plan View | 8.11             | 41          |
| <b>Junction Details</b>                  | Horizontal Control Joint  | 8.12             | 42          |
|  | Junction at Soffit and External Roofing   | 8.13             | 42          |
|  | Junction with Soffit and External Roofing   | 8.14             | 42          |
|  | Junction with External Pitched Soffit   | 8.15             | 42          |
| <b>Window Details</b>                    | Typical Window Head, Sill and Jamb Detail   | 8.16             | 43          |
|  | Typical Window Head - Front Elevation   | 8.17             | 43          |
|  | Typical Window Head, Sill and Jamb Detail   | 8.18             | 43          |
|  | Smartfit Window Head, Sill and Jamb Detail  | 8.19             | 44          |
|  | Typical Commercial Window Head, Sill and Jamb Detail                                    | 8.20             | 44          |
| <b>Garage Door and Meter Box Details</b> | Typical Garage Door Jamb Detail   | 8.21             | 45          |
|  | Typical Garage Door Head Detail   | 8.22             | 45          |
|  | Typical Penetration   | 8.23             | 45          |
|  | No Soffit wall detail   | 8.24             | 45          |
|  | Typical Power Meter Box Installation – Elevation  | 8.25             | 46          |

## CONSTRUCTION DRAWINGS AND DETAILS



Note: Drawings are interchangeable for timber or steel substrates with the exception of the fasteners.

| SECTION                                | DESCRIPTION   | FIGURE REFERENCE | PAGE NUMBER |
|--|---|------------------|-------------|
| <b>Additional Junction Details</b>     | Vertical Junction Between Horizontal Territory Panel and Vertical Territory Panel | 8.26             | 47          |
|  | Internal Corner Junction Panel to Brick Veneer                                    | 8.27             | 47          |
|  | Abutment Panel to Brick Veneer  | 8.28             | 47          |
|  | External Corner Junction Panel to Brick Veneer                                    | 8.29             | 48          |
|  | Internal Corner Junction Panel/Bond Wall  | 8.30             | 48          |
|  | External Corner Junction Panel/ Weatherboard                                      | 8.31             | 48          |
|  | Internal Corner Junction Panel/Weatherboard                                       | 8.32             | 48          |
|  | Vertical Abutment Panel/Weatherboard  | 8.33             | 49          |
|  | Typical Junction with In-line Masonry Wall – Plan View                            | 8.34             | 49          |
|  | Second Storey Junction with Brick Veneer or Masonry Wall – Cantilevered Framing   | 8.35             | 49          |
|  | Typical Junction with Offset Masonry Wall – Plan View                             | 8.36             | 49          |
|  | Typical Junction with Fibre Cement Cladding System – Plan View                    | 8.37             | 50          |
|  | Second Storey Junction with Masonry or Brick Veneer – In-line Framing             | 8.38             | 50          |
|  | Typical Balcony Rail  | 8.39             | 50          |
|  | Two Sided Parapet – Elevation   | 8.40             | 50          |
| <b>Base, Soffit and Corner Details</b> | Typical Base Detail – Elevation   | 8.41             | 51          |
|  | Typical Internal Corner Detail – Elevation  | 8.42             | 51          |
|  | Typical Soffit Detail – Elevation   | 8.43             | 51          |
|  | Typical External Corner Detail with Metal Corner Trim – Elevation                 | 8.44             | 51          |
|  | Typical Horizontal Control Joint – Elevation                                      | 8.45             | 52          |
|  | Typical Sealant Filled Vertical Joint Detail – Plan                               | 8.46             | 52          |
|  | Alternative Sealant Filled Vertical Joint Detail – Plan                           | 8.47             | 52          |
|  | Typical Parapet Detail – Elevation  | 8.48             | 52          |
| <b>Masonry Details</b>                 | Typical Domestic Window Head, Sill and Jamb Detail                                | 8.49             | 53          |
|  | Typical Commercial Window Head, Sill and Jamb Detail                              | 8.50             | 53          |
|  | Typical Power Meter Box Installation – Elevation                                  | 8.51             | 54          |





## CONSTRUCTION DRAWINGS AND DETAILS

Note: Drawings are interchangeable for timber or steel substrates with the exception of the fasteners.

### Base Details

**FIGURE 8.01** Base Detail – 90mm Framing Shown

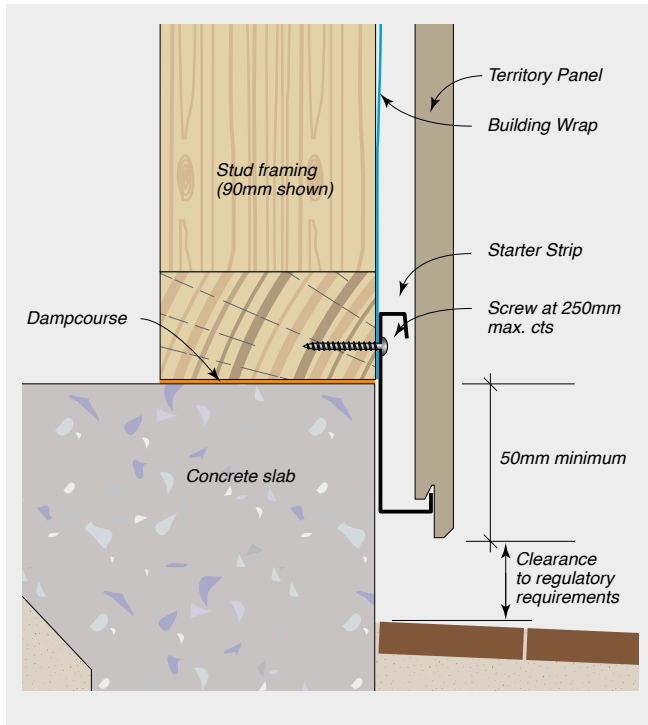

**FIGURE 8.02** Base Detail – 70mm Framing Shown

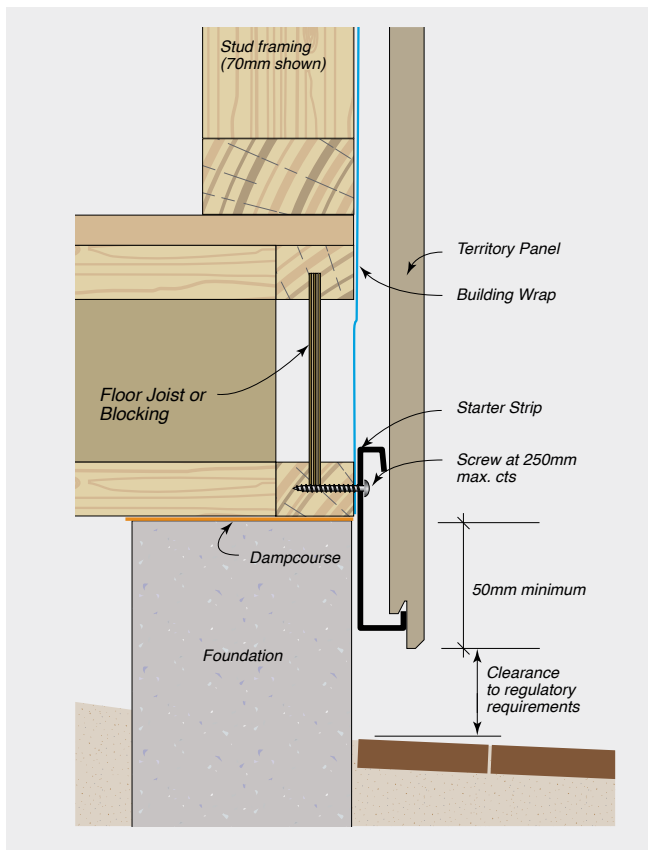

**FIGURE 8.03** Alternate Base Fixing Detail

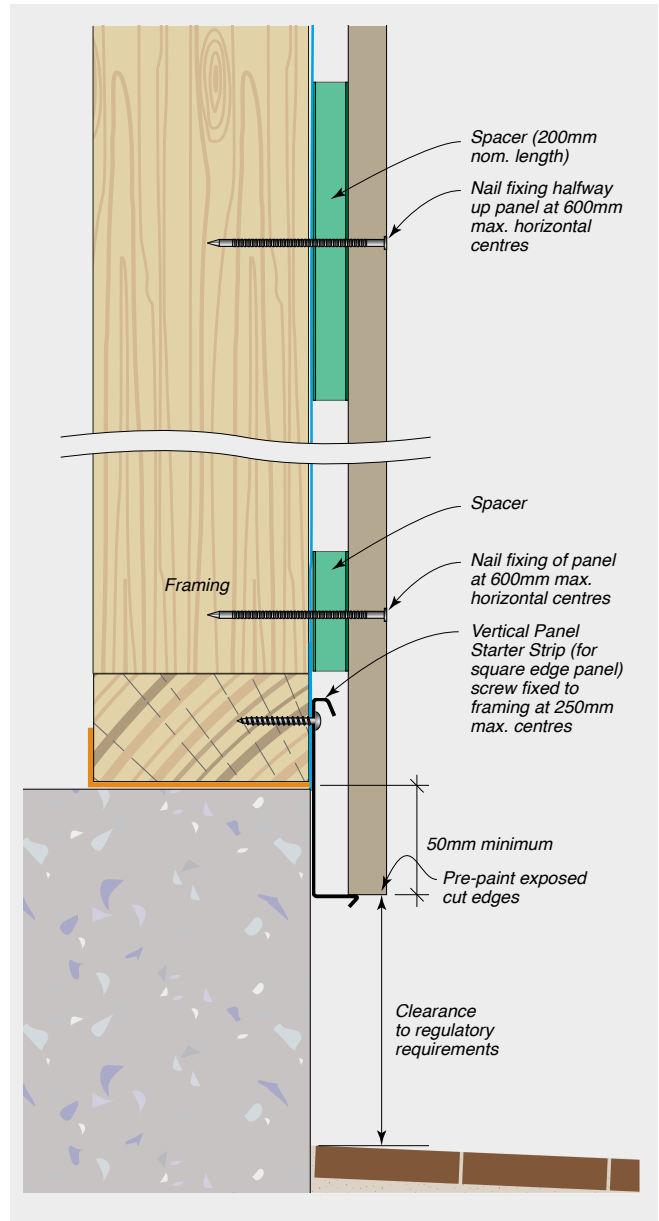

## CONSTRUCTION DRAWINGS AND DETAILS



Note: Drawings are interchangeable for timber or steel substrates with the exception of the fasteners.

### Soffit Details

At eaves line the Territory Panel system must be provided with cavity ventilation. Panels are trimmed to appropriate height and face fixed through the Spacer into the framing. Refer to the following detail options.

**FIGURE 8.04** Soffit Detail - With Coloured Eaves Trim - Elevation

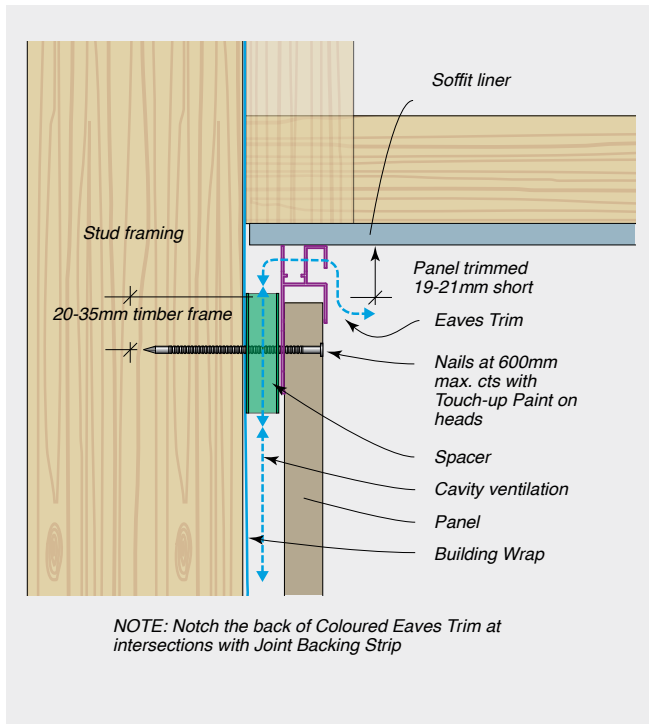

**FIGURE 8.06** Soffit Detail

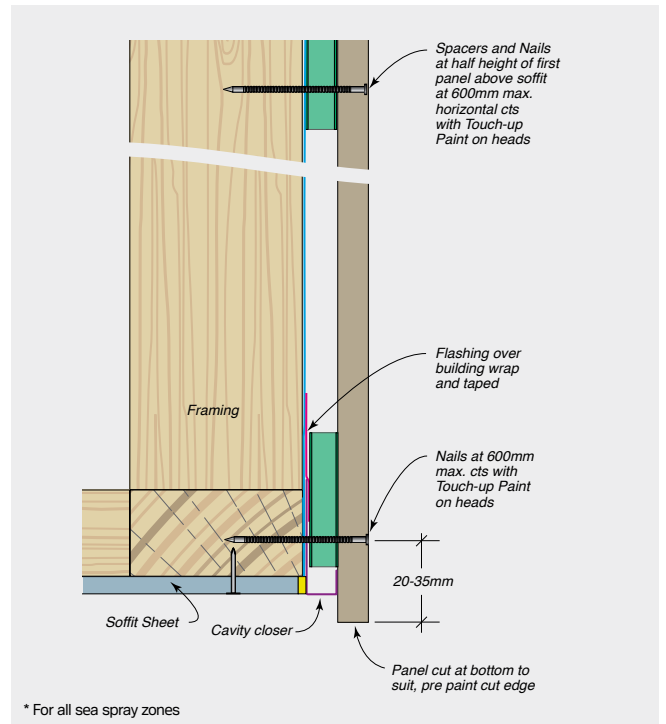

**FIGURE 8.05** Alternative Soffit Detail - With Timber Trim - Elevation

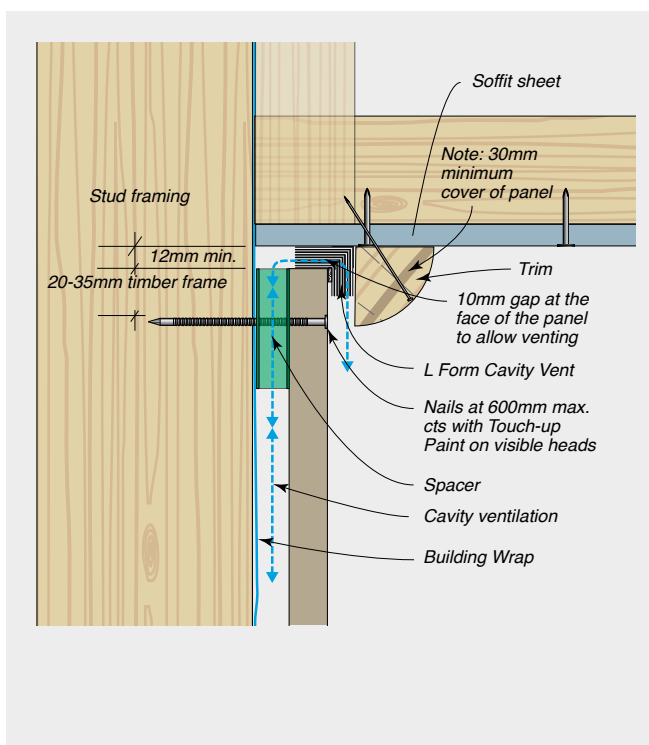

**FIGURE 8.07** Soffit Detail - With Soffit Trim - Elevation

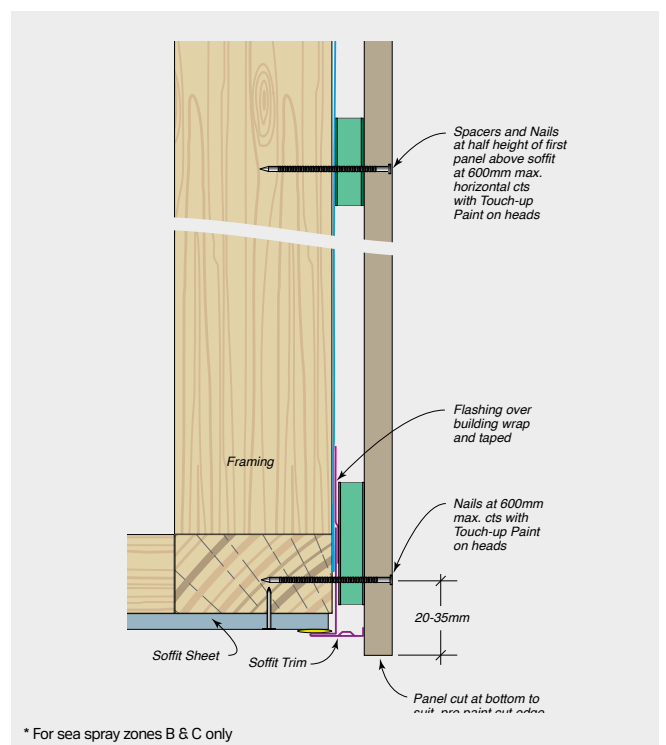



## CONSTRUCTION DRAWINGS AND DETAILS

Note: Drawings are interchangeable for timber or steel substrates with the exception of the fasteners.

### Corner Details

Additional studs may be required at corners to allow for fixing Panel Clips and other components.

**FIGURE 8.08** External Corner Detail – With Preformed Corner – Plan View

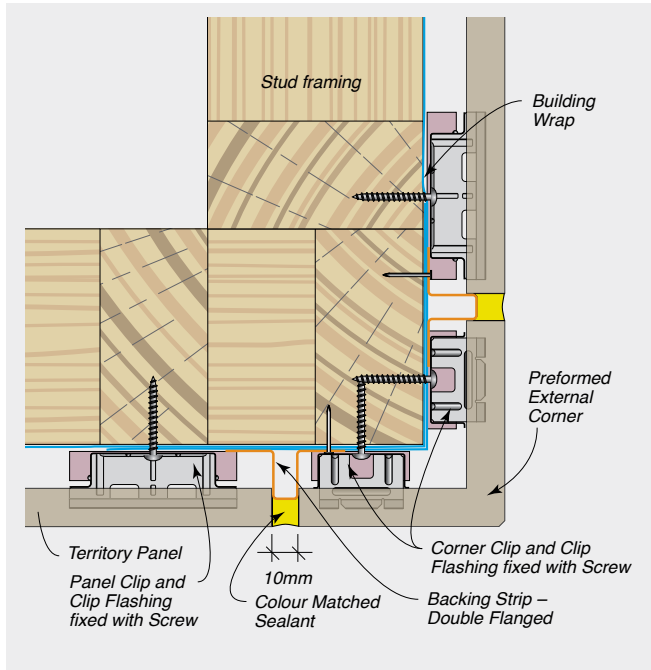

**FIGURE 8.10** Internal Corner Detail – With Backing Strip and Colour Matched Sealant – Plan View

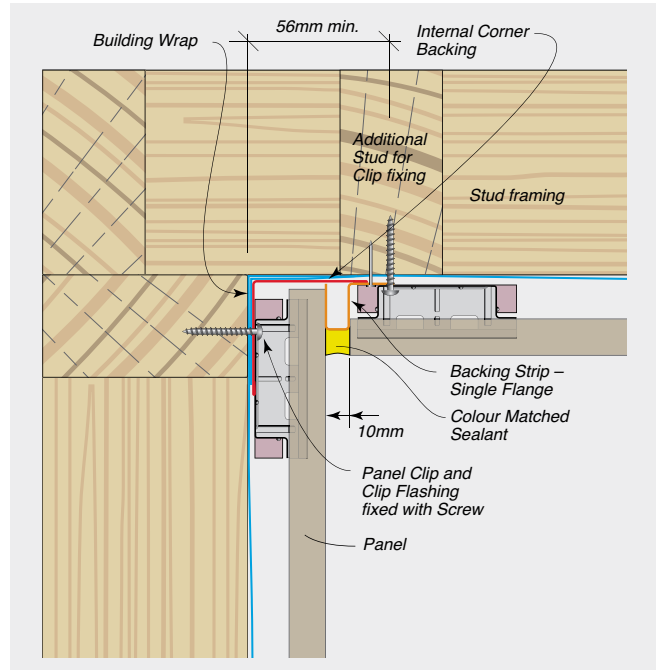

**FIGURE 8.09** External Corner Detail – With Coloured External Corner Trim – Plan View

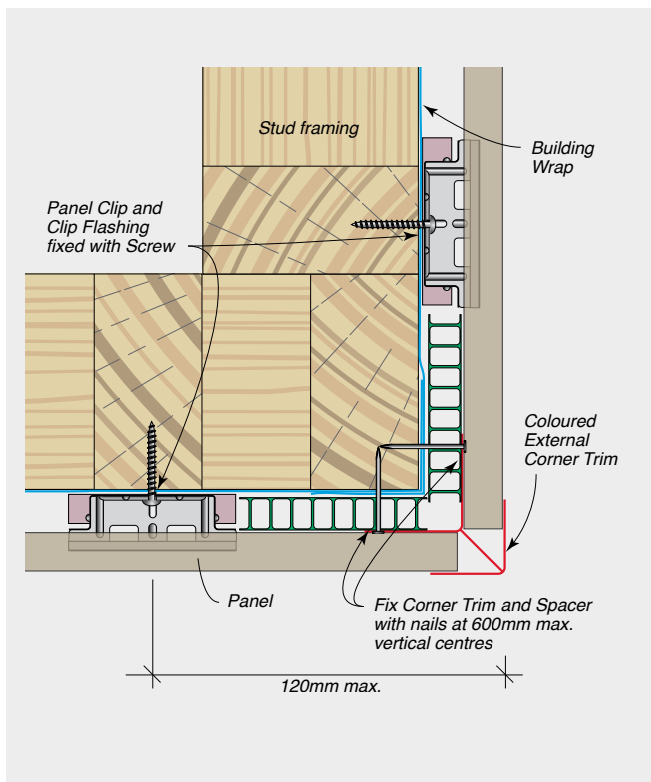

**FIGURE 8.11** Obtuse Angle Corner Detail – With Metal Flashing and Colour Matched Sealant – Plan View

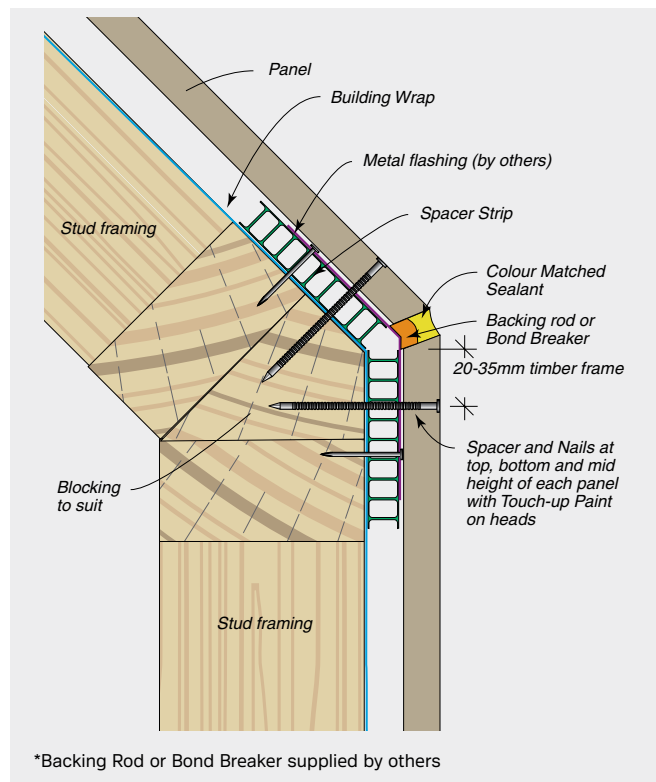

## CONSTRUCTION DRAWINGS AND DETAILS



Note: Drawings are interchangeable for timber or steel substrates with the exception of the fasteners.

### Junction Details

**FIGURE 8.12** Horizontal Control Joint

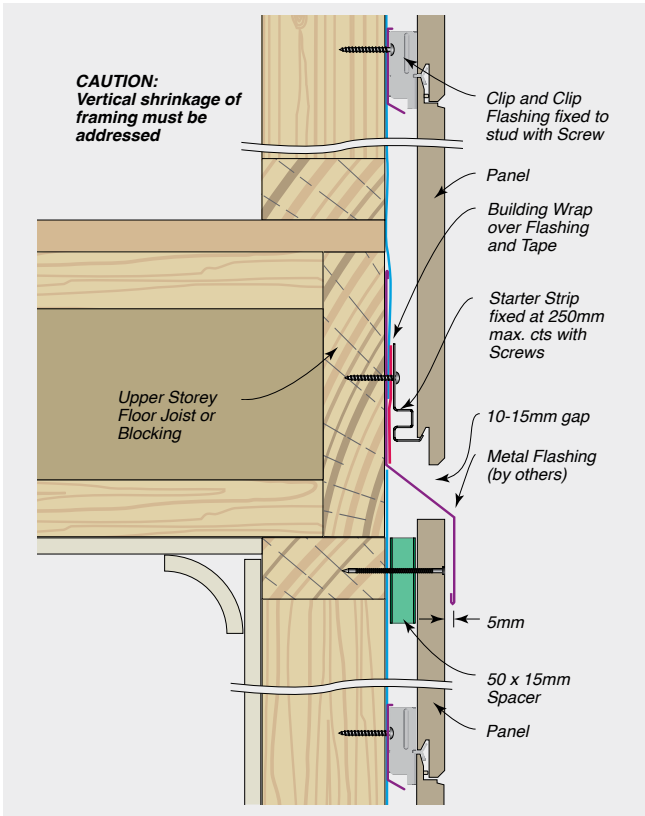

**FIGURE 8.14** Junction with Soffit and External Roofing

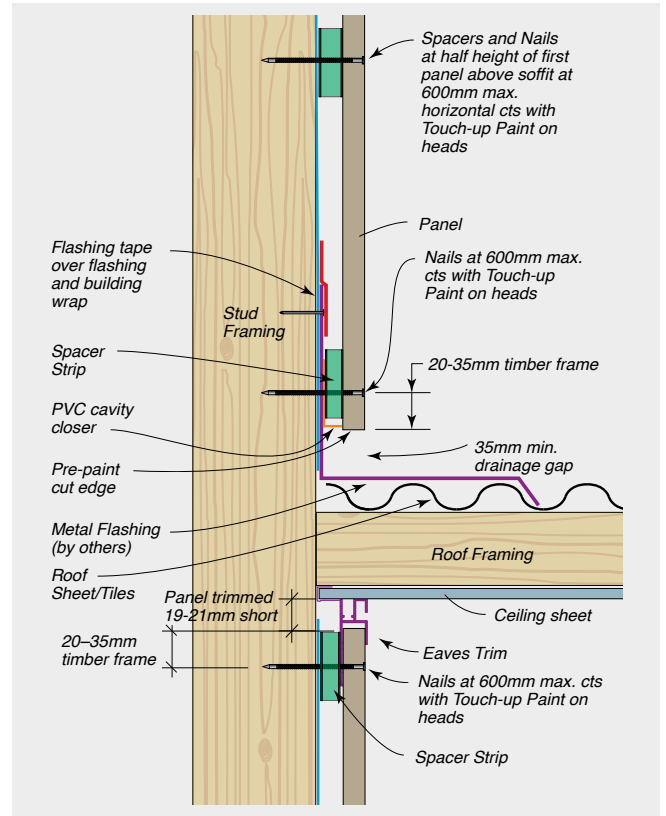

**FIGURE 8.13** Junction at Soffit and External Roofing

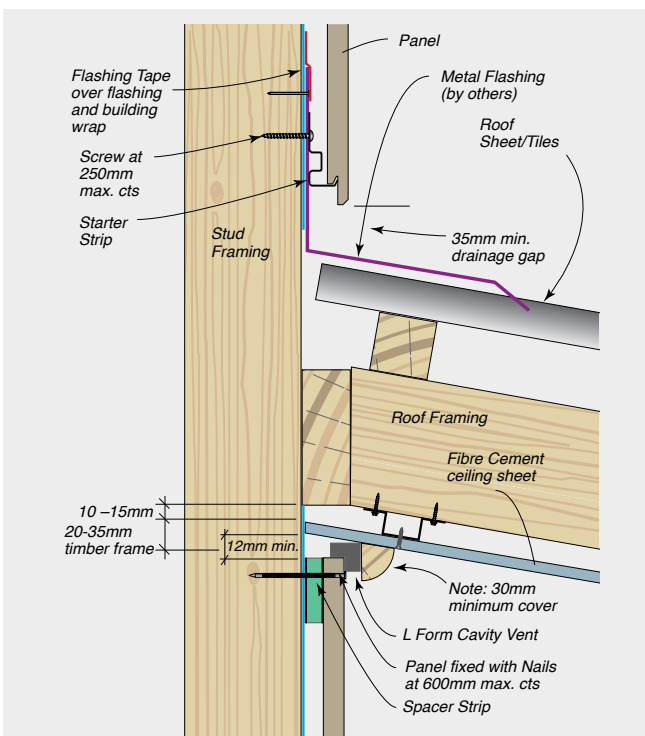

**FIGURE 8.15** Junction with External Pitched Soffit

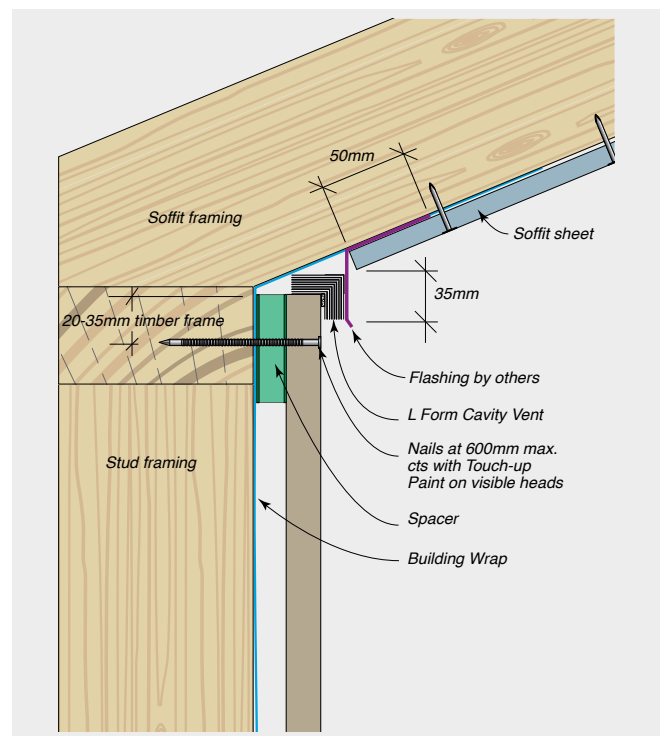



# CONSTRUCTION DRAWINGS AND DETAILS

Note: Drawings are interchangeable for timber or steel substrates with the exception of the fasteners.

## Window Details

**FIGURE 8.16** Typical Window Head, Sill and Jamb Detail

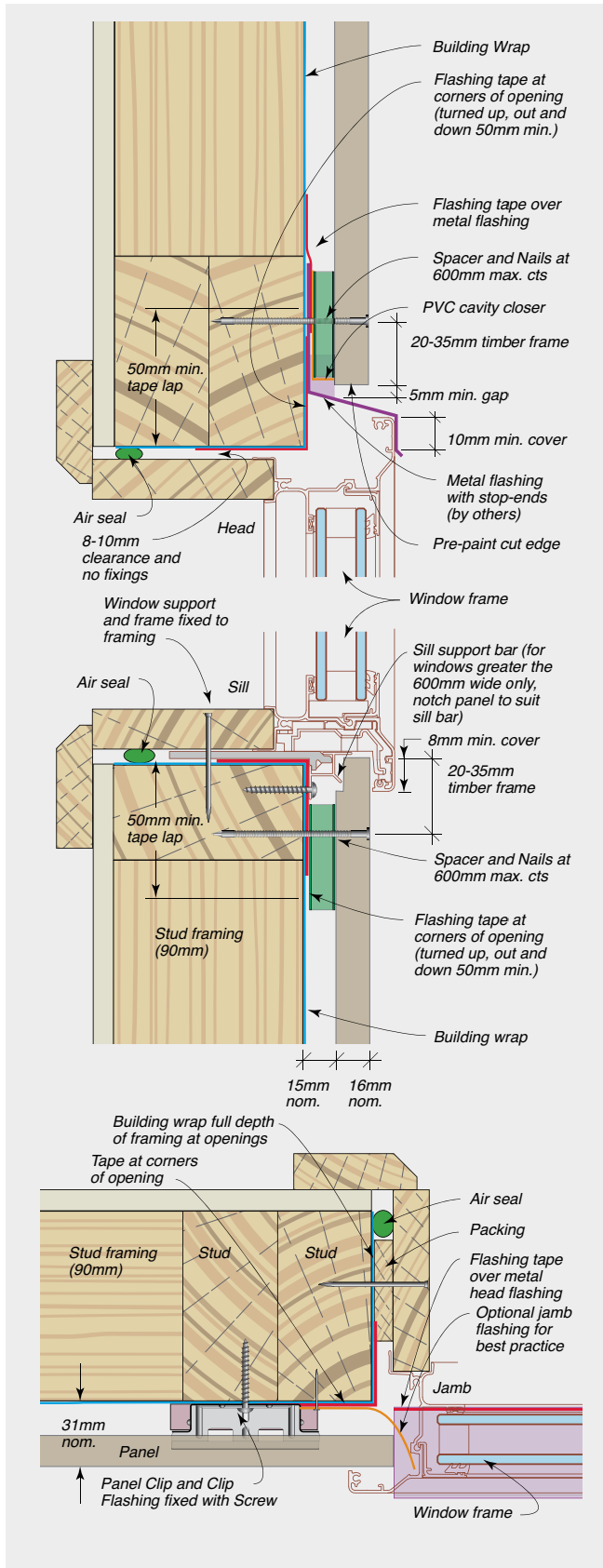

**FIGURE 8.17** Typical Window Head - Front Elevation

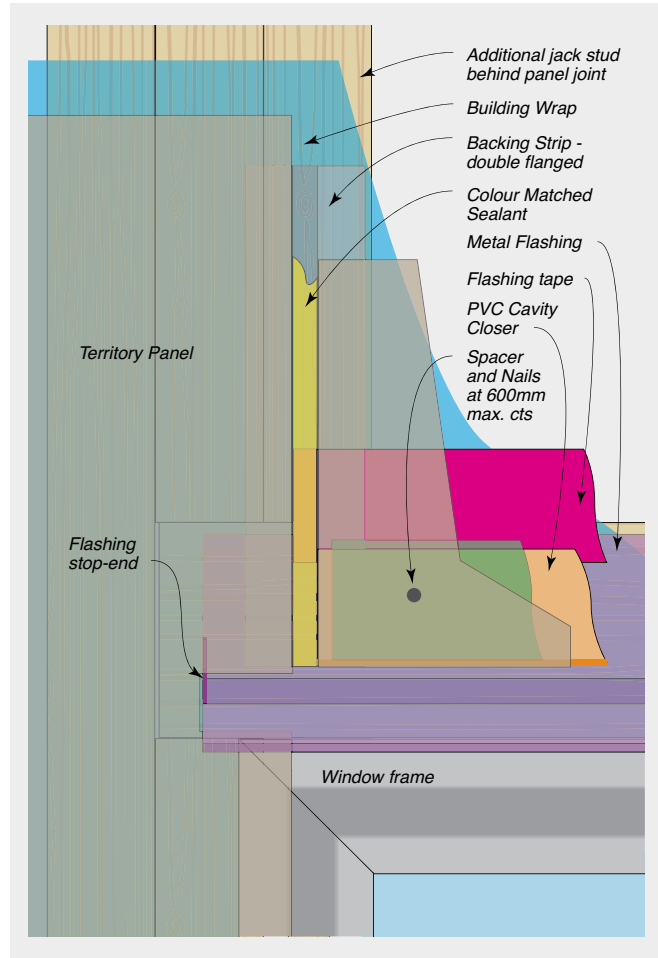

**FIGURE 8.18** Alternative Window Head Detail

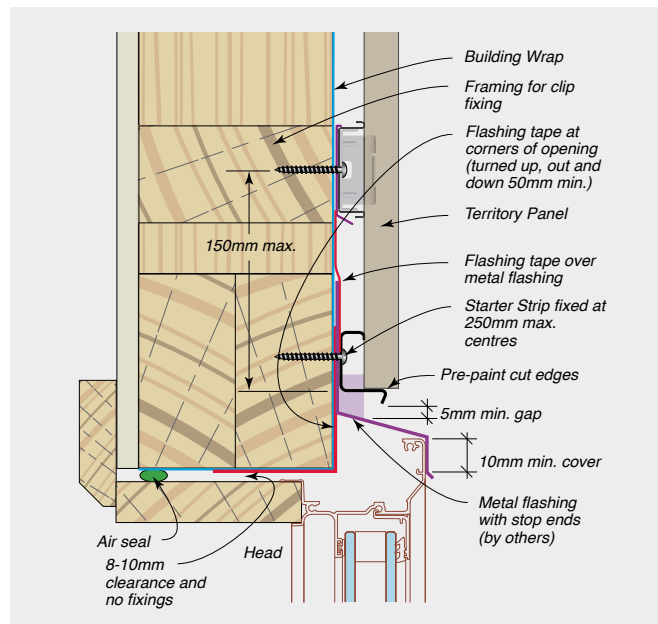

## CONSTRUCTION DRAWINGS AND DETAILS



Note: Drawings are interchangeable for timber or steel substrates with the exception of the fasteners.

**FIGURE 8.19** Smartfit Window Head, Sill and Jamb Detail

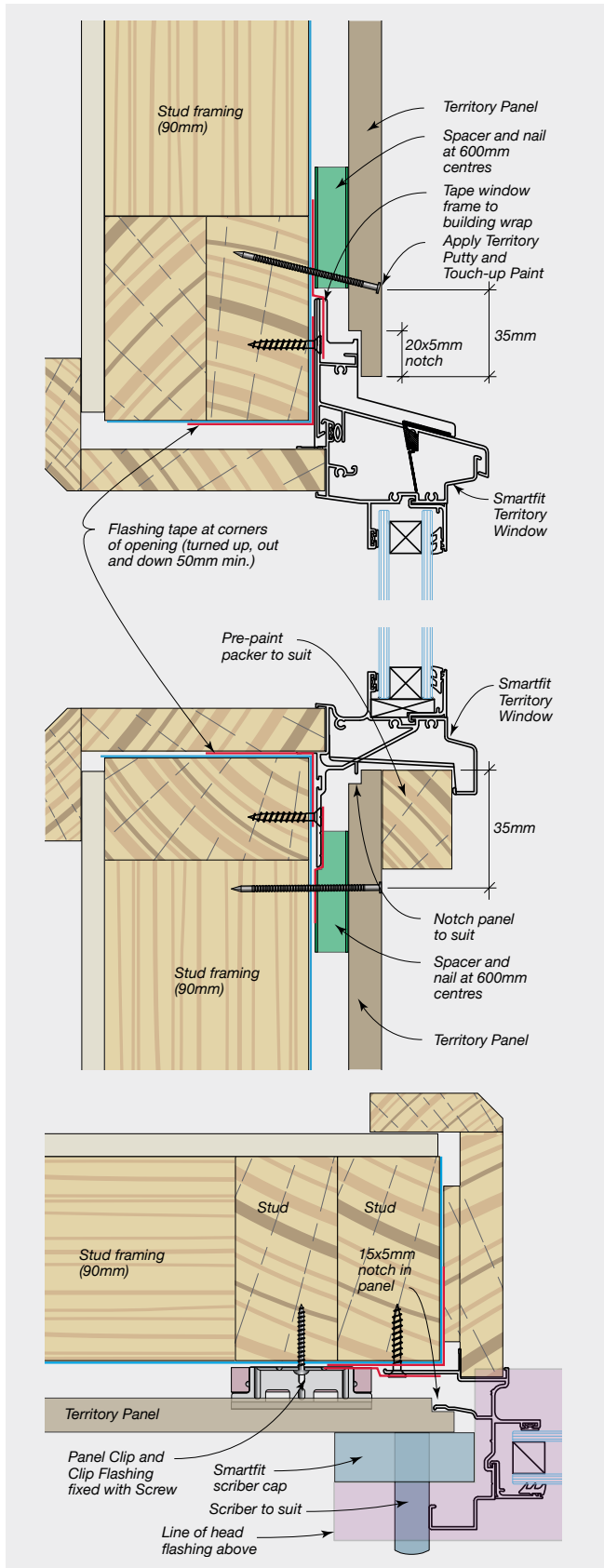

**FIGURE 8.20** Typical Commercial Window Head, Sill and Jamb Detail

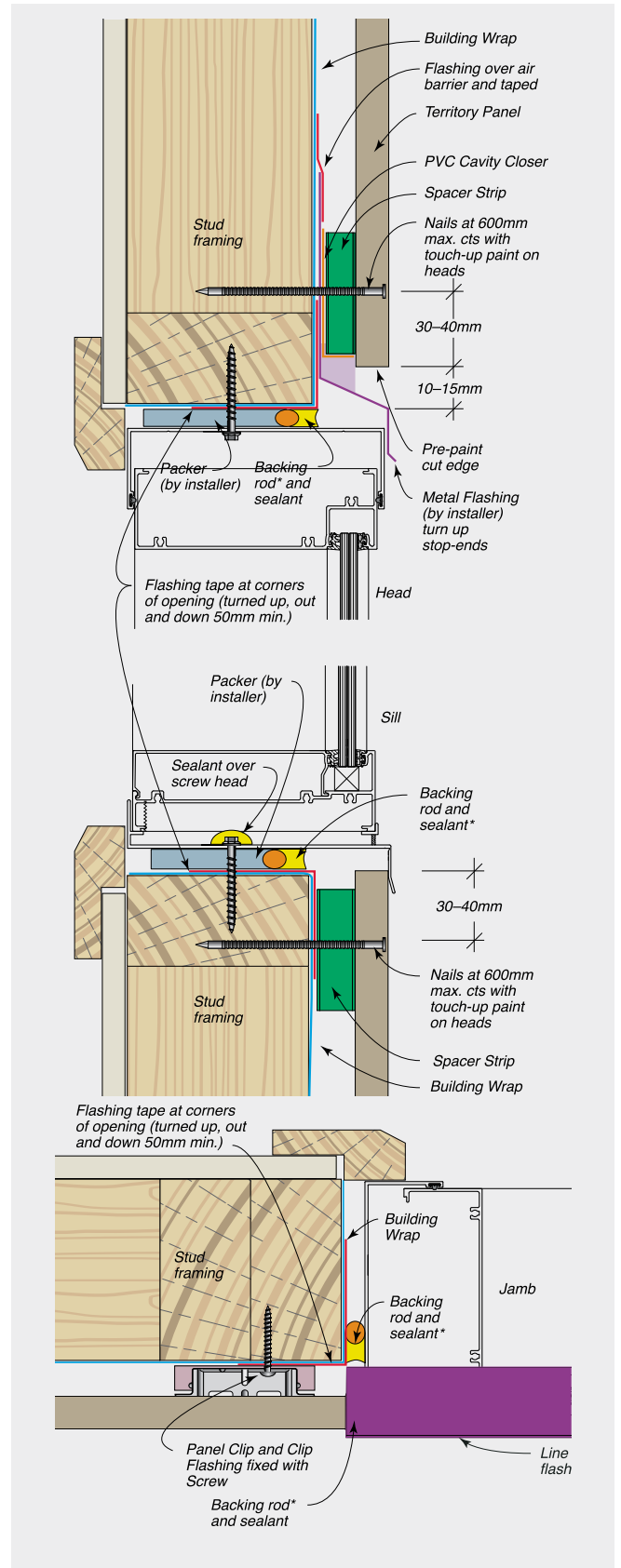





## CONSTRUCTION DRAWINGS AND DETAILS

Note: Drawings are interchangeable for timber or steel substrates with the exception of the fasteners.

### Garage Door and Meter Box Details

**FIGURE 8.21** Typical Garage Door Jamb Detail

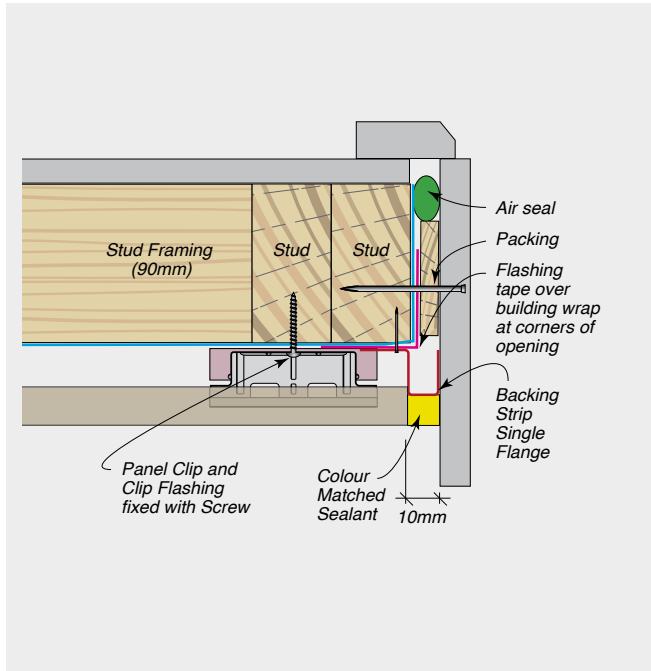

**FIGURE 8.23** Typical Garage Door Head Detail

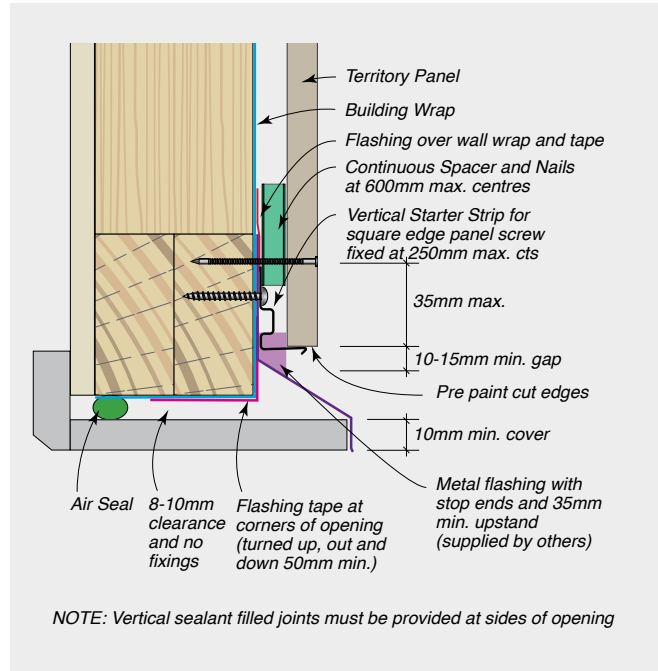

**FIGURE 8.22** Typical Penetration

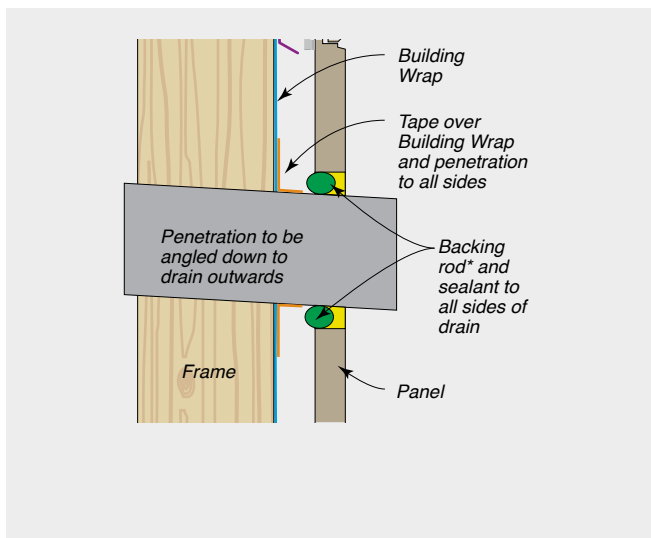

**FIGURE 8.24** No Soffit wall detail

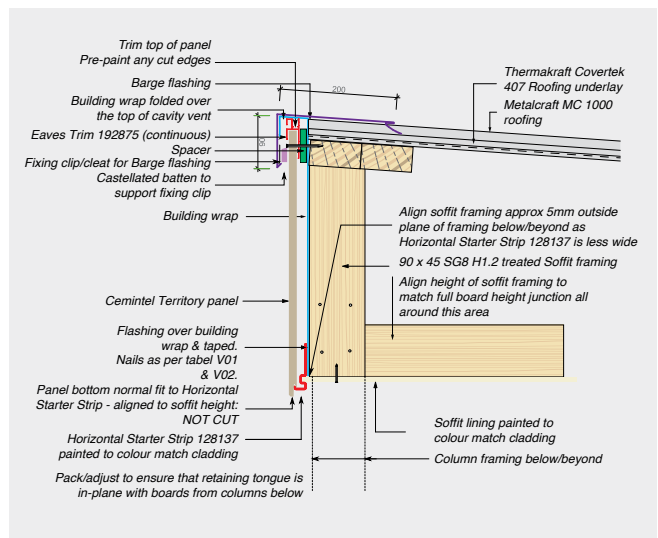

## CONSTRUCTION DRAWINGS AND DETAILS



Note: Drawings are interchangeable for timber or steel substrates with the exception of the fasteners.

**FIGURE 8.25** Typical Power Meter Box Installation – Elevation

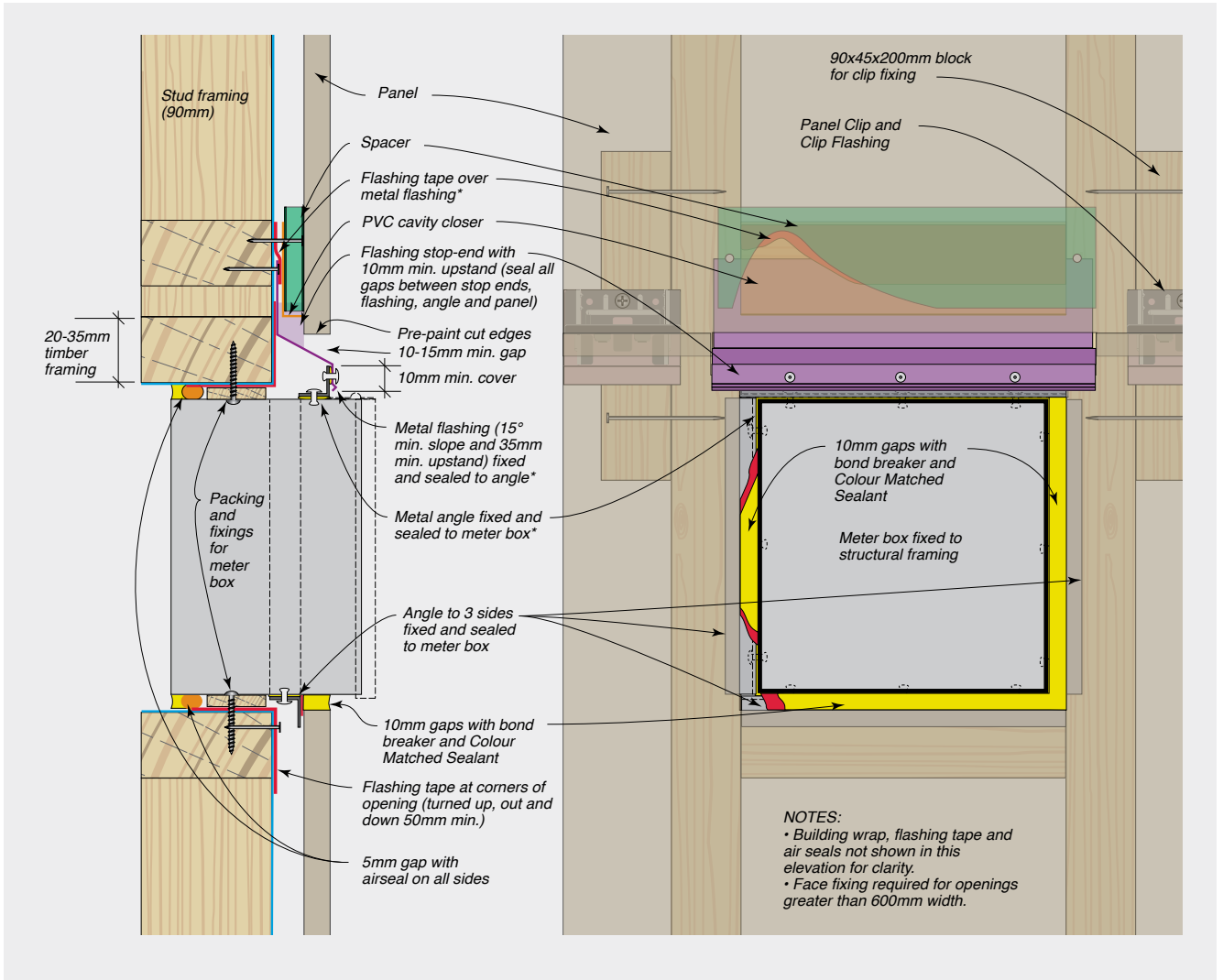





## CONSTRUCTION DRAWINGS AND DETAILS

Note: Drawings are interchangeable for timber or steel substrates with the exception of the fasteners.

### Additional Junction Details

**FIGURE 8.26** Vertical Junction Between Horizontal Territory Panel and Vertical Territory Panel

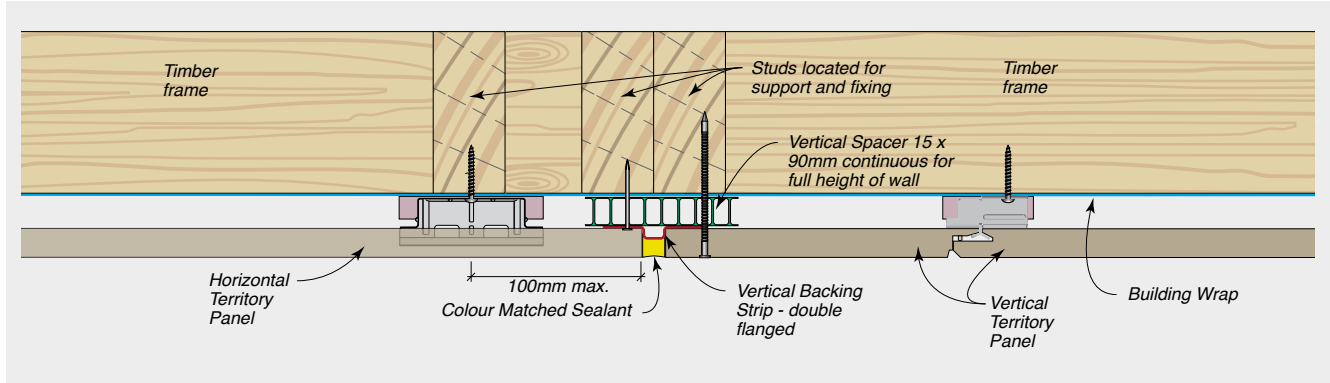

**FIGURE 8.27** Internal Corner Junction Panel to Brick Veneer

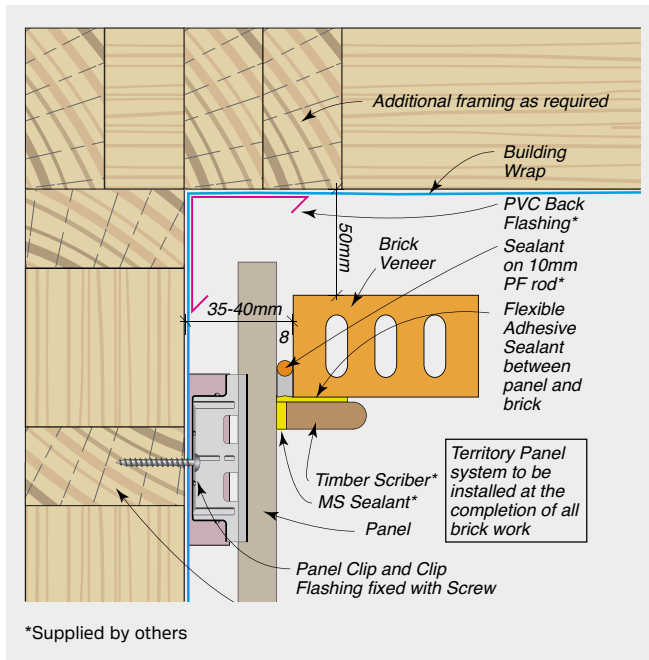

**FIGURE 8.28** Abutment Panel to Brick Veneer

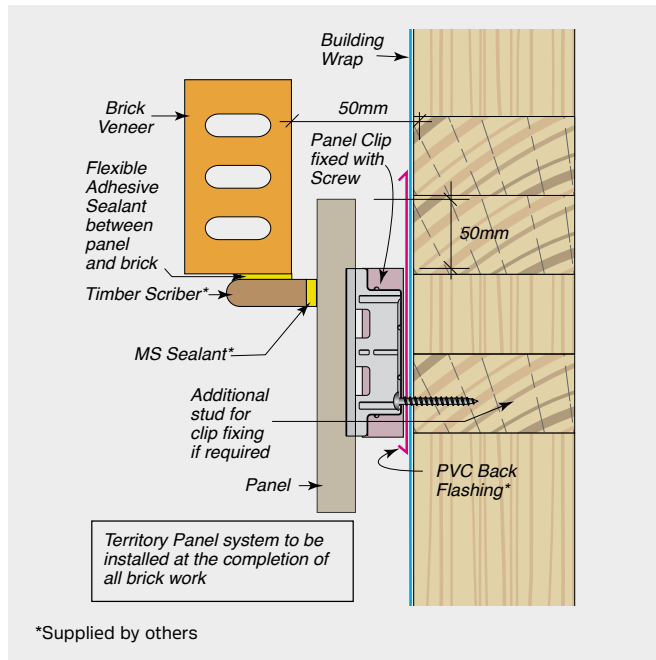

\*Supplied by others

\*Supplied by others

## CONSTRUCTION DRAWINGS AND DETAILS



Note: Drawings are interchangeable for timber or steel substrates with the exception of the fasteners.

**FIGURE 8.29** External Corner Junction Panel to Brick Veneer

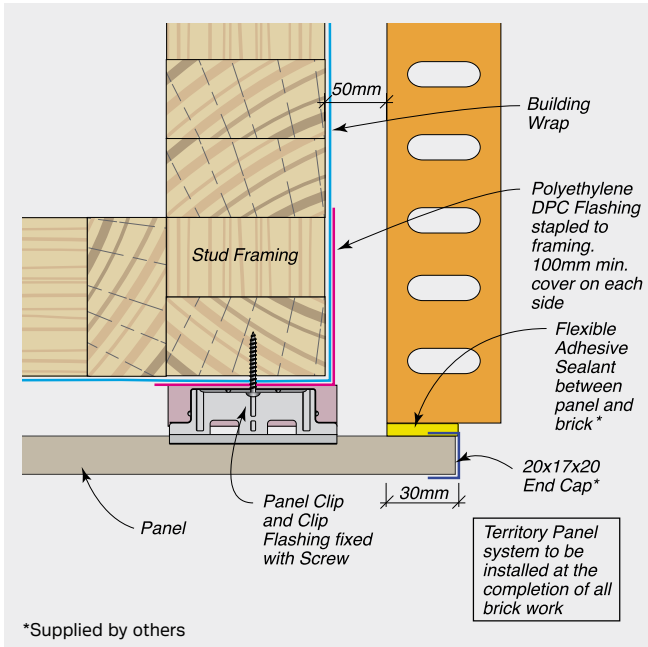

**FIGURE 8.30** Internal Corner Junction Panel/Bond Wall

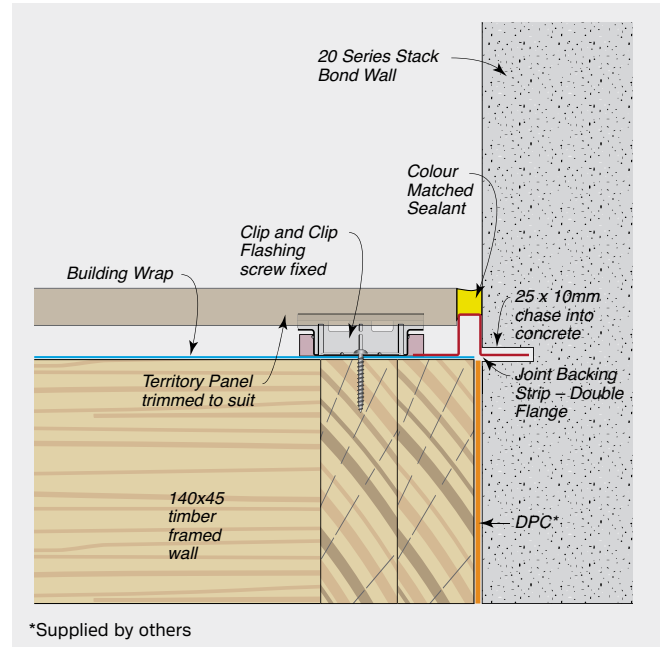

**FIGURE 8.31** External Corner Junction Panel/ Weatherboard

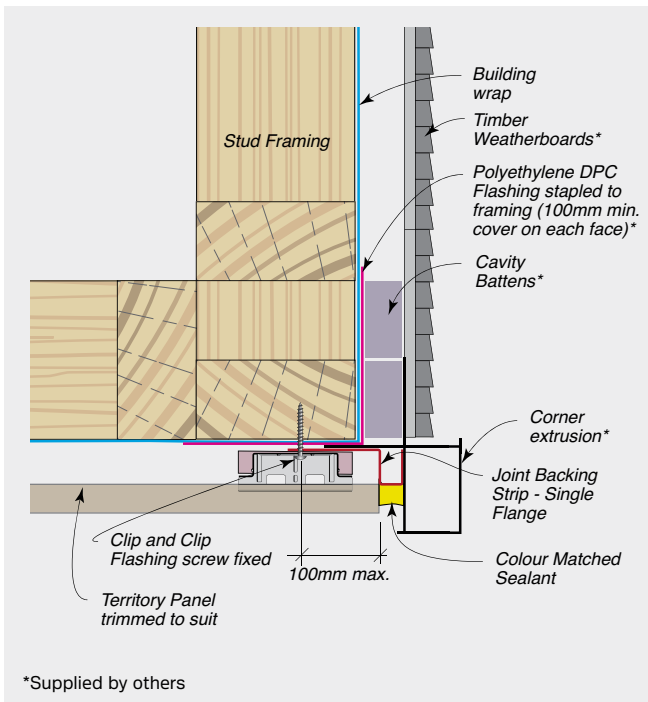

**FIGURE 8.32** Internal Corner Junction Panel/Weatherboard

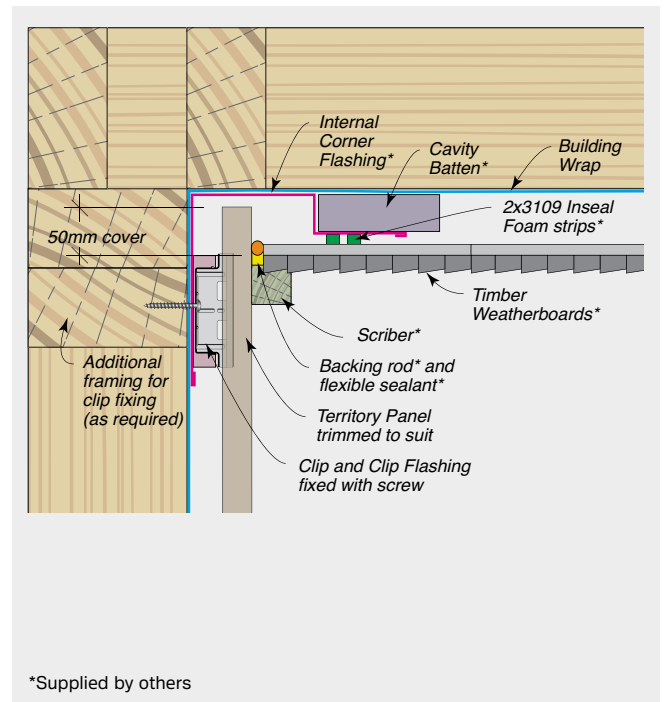



## CONSTRUCTION DRAWINGS AND DETAILS

Note: Drawings are interchangeable for timber or steel substrates with the exception of the fasteners.

**FIGURE 8.33** Vertical Abutment Panel/Weatherboard

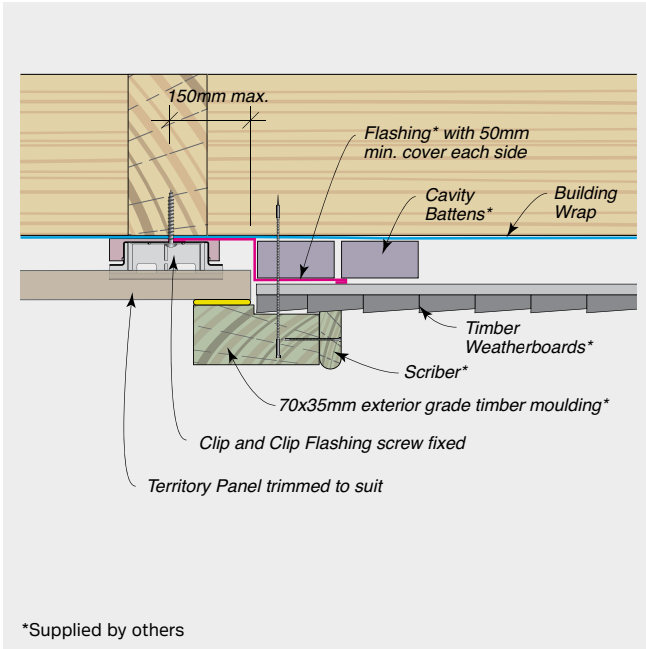

**FIGURE 8.34** Typical Junction with In-line Masonry Wall – Plan View

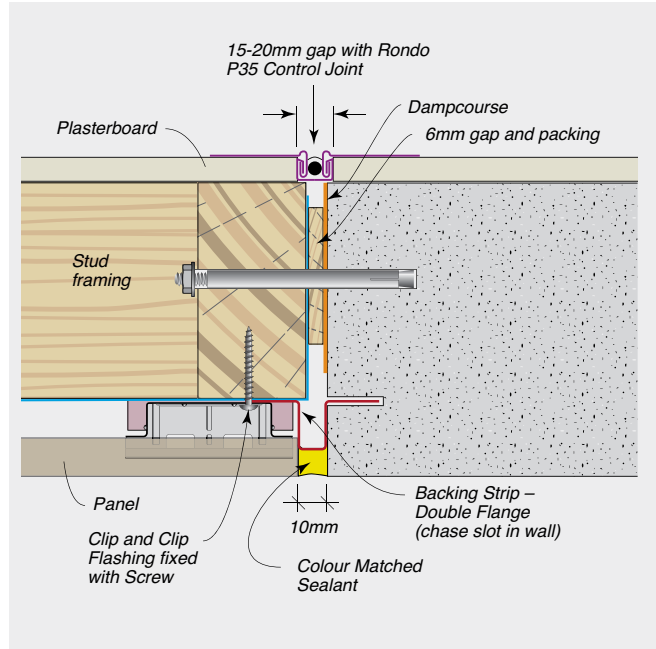

**FIGURE 8.35** Second Storey Junction with Brick Veneer or Masonry Wall – Cantilevered Framing

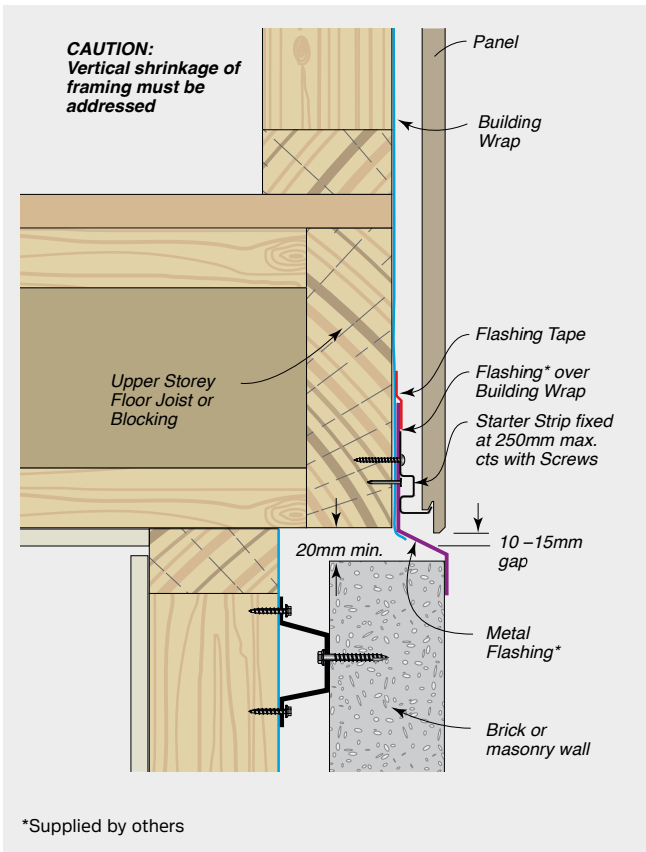

**FIGURE 8.36** Typical Junction with Offset Masonry Wall – Plan View

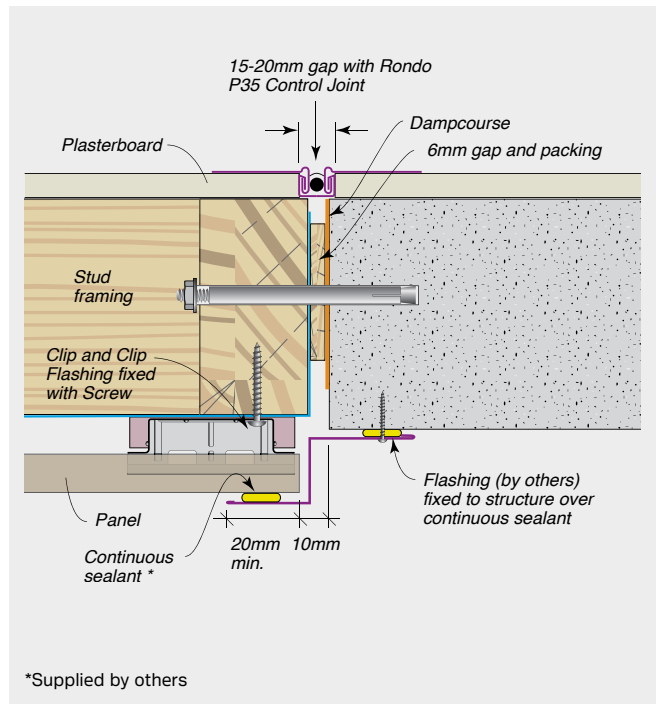

## CONSTRUCTION DRAWINGS AND DETAILS



Note: Drawings are interchangeable for timber or steel substrates with the exception of the fasteners.

**FIGURE 8.34** Typical Junction with Fibre Cement Cladding System - Plan View

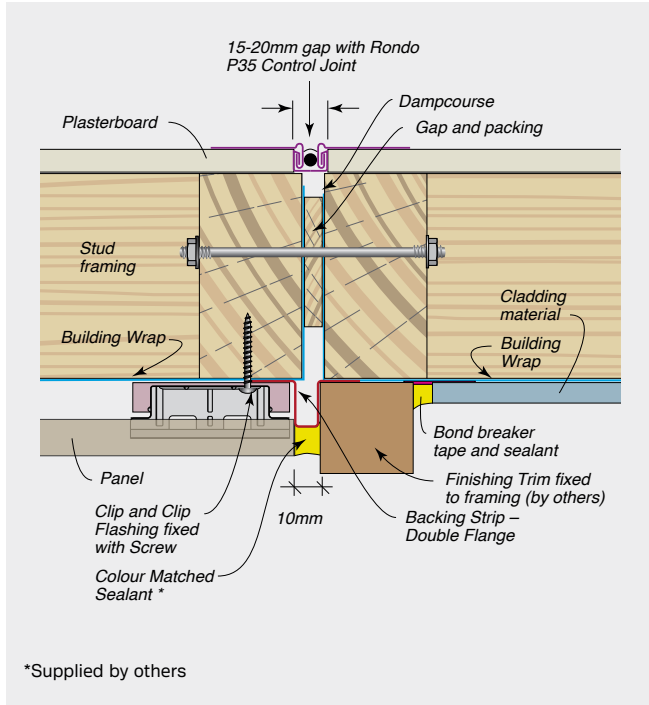

**FIGURE 8.35** Second Storey Junction with Masonry or Brick Veneer - In-line Framing

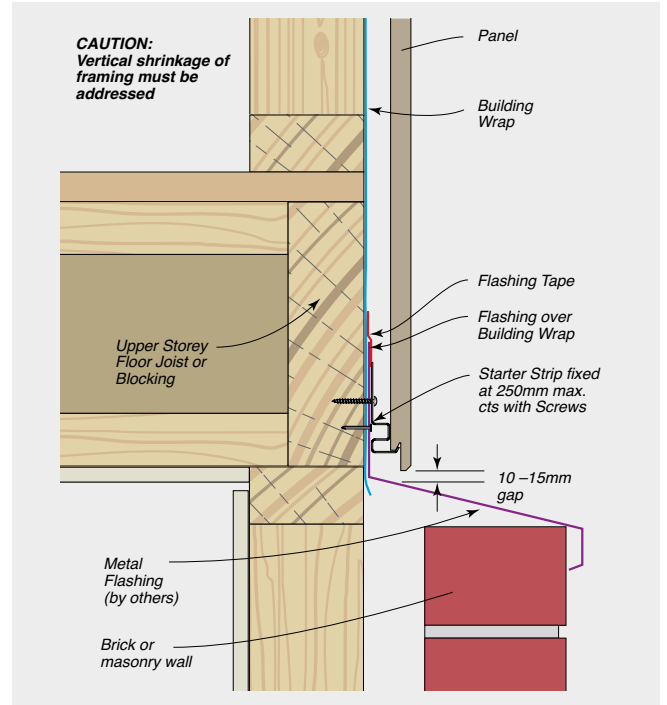

**FIGURE 8.36** Typical Balcony Rail

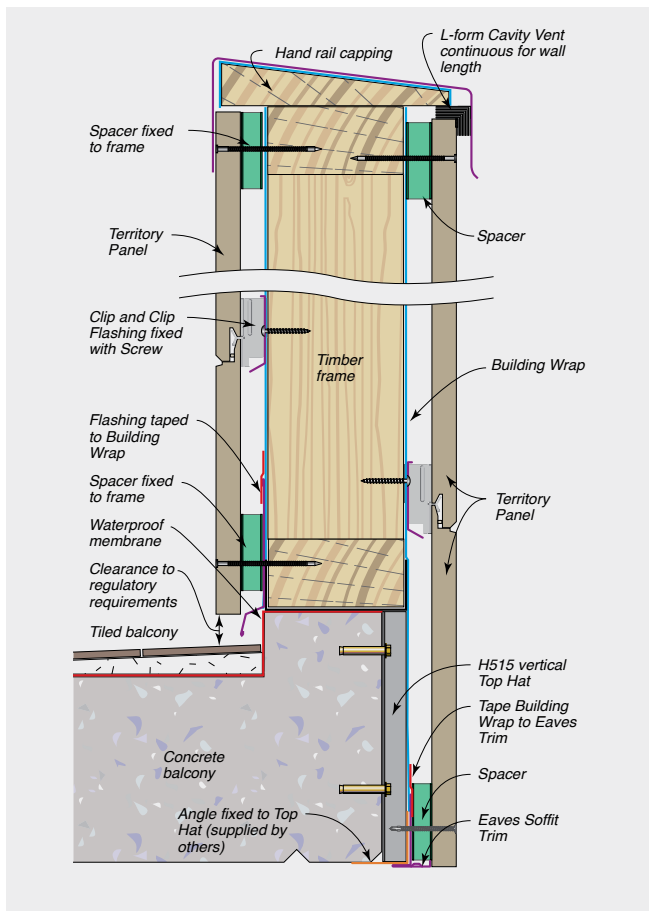

**FIGURE 8.37** Two Sided Parapet - Elevation

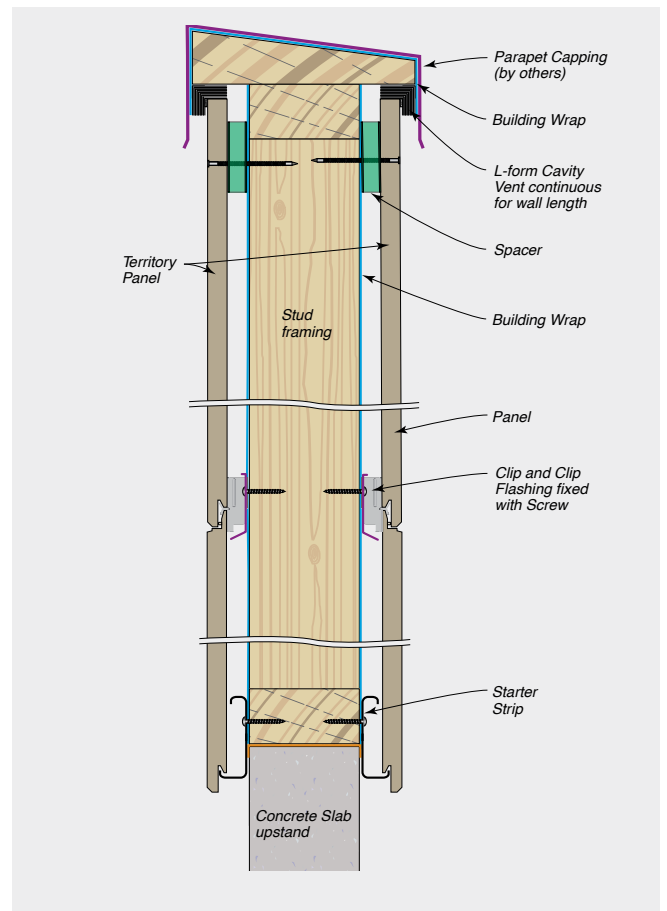



## CONSTRUCTION DRAWINGS AND DETAILS

Note: Drawings are interchangeable for timber or steel substrates with the exception of the fasteners.

### Base, Soffit and Corner Details

**FIGURE 8.41** Typical Base Detail – Elevation

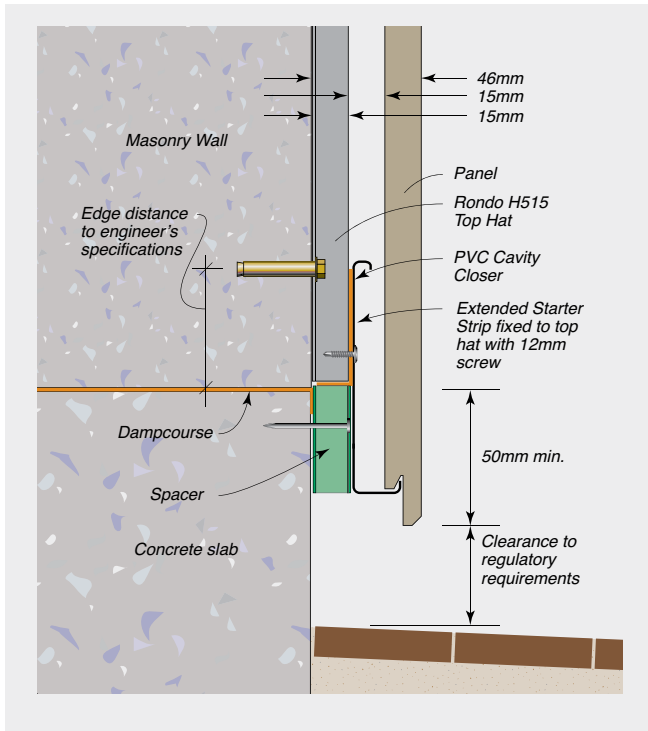

**FIGURE 8.42** Typical Internal Corner Detail – Elevation

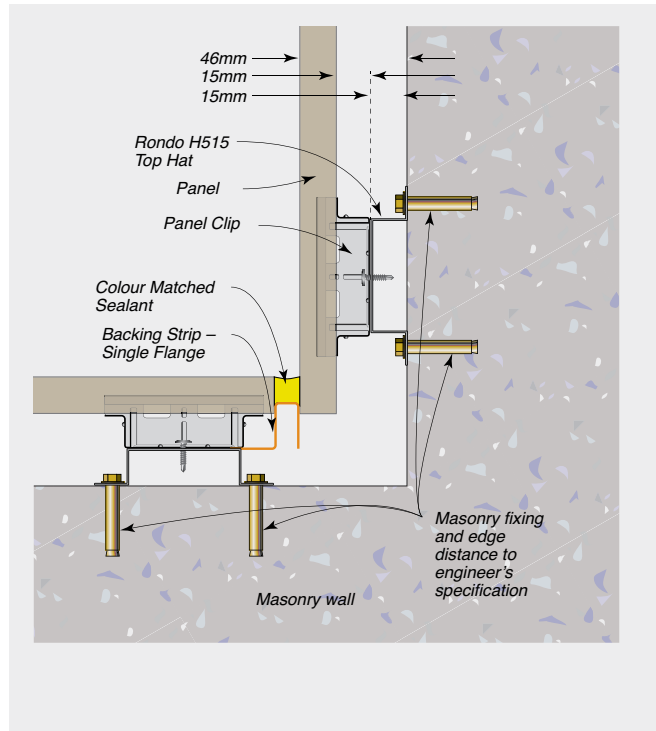

**FIGURE 8.43** Typical Soffit Detail – Elevation

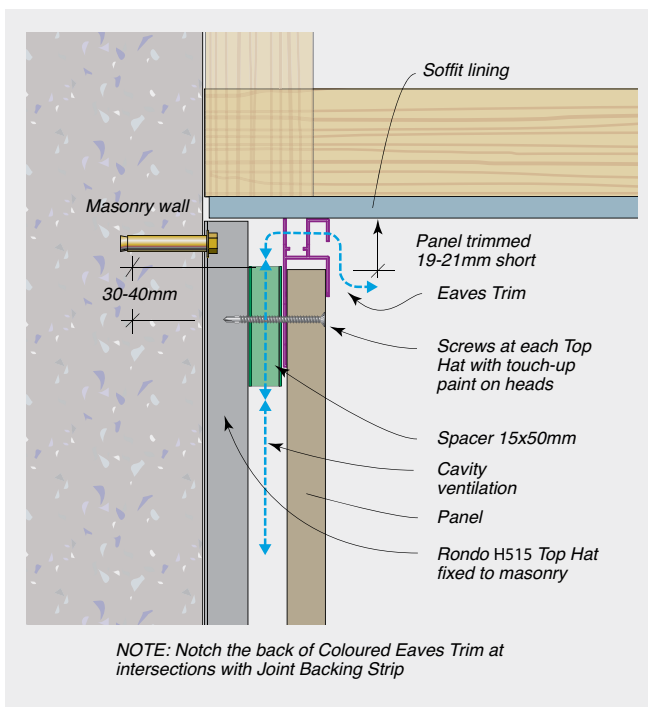

**FIGURE 8.44** Typical External Corner Detail with Metal Corner Trim – Elevation

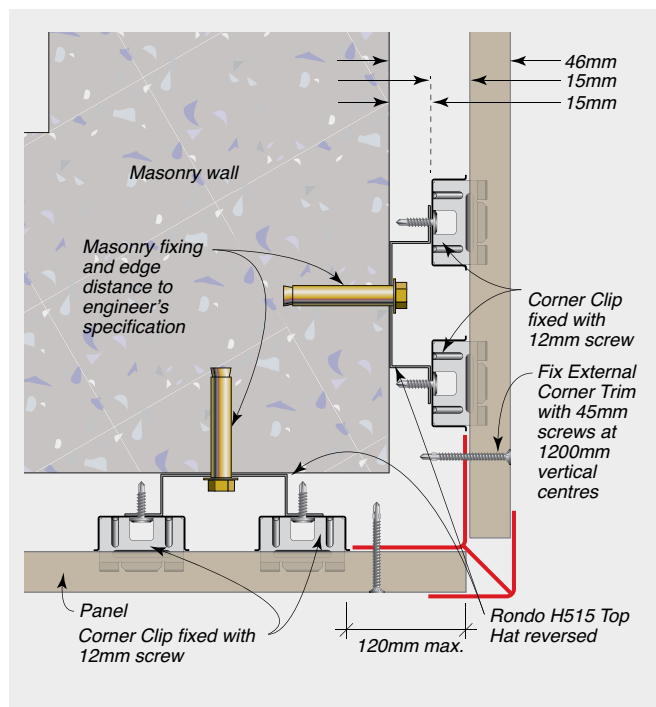

# CONSTRUCTION DRAWINGS AND DETAILS



Note: Drawings are interchangeable for timber or steel substrates with the exception of the fasteners.

**FIGURE 8.45** Typical Horizontal Control Joint – Elevation

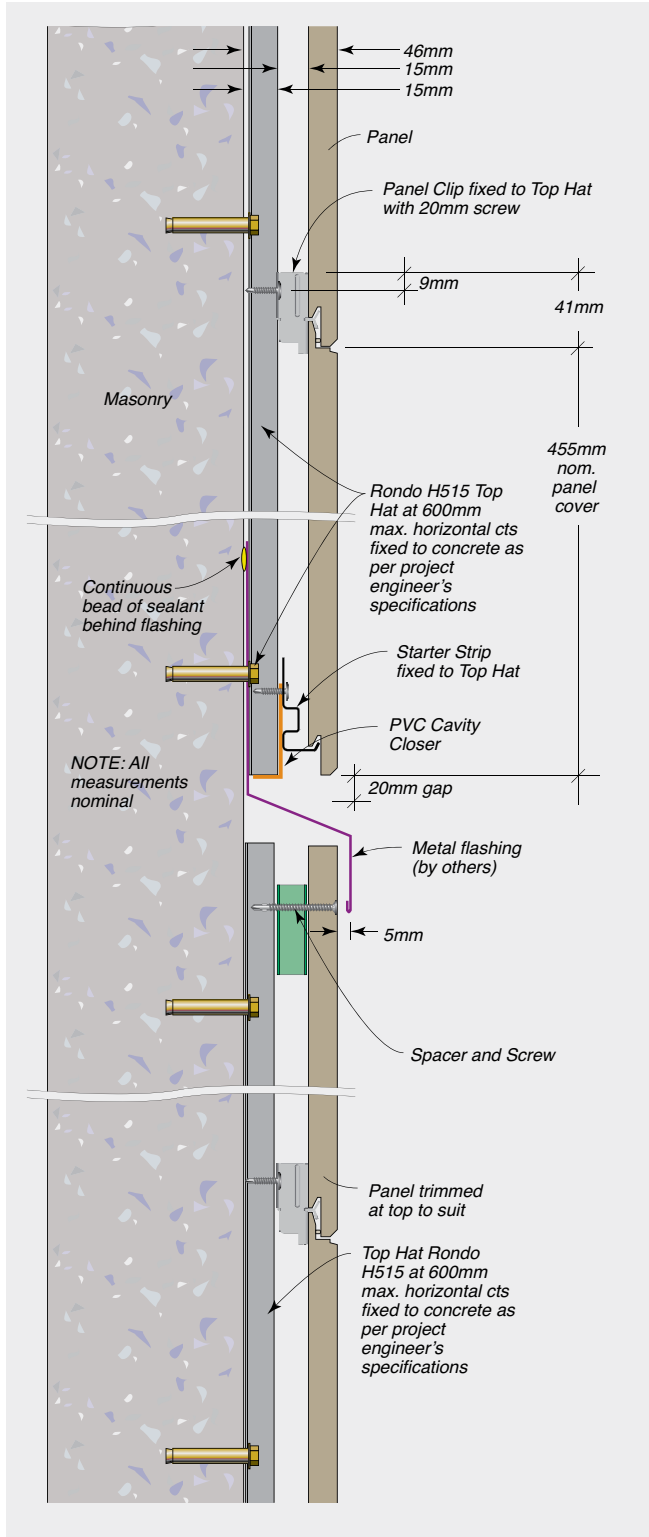

**FIGURE 8.46** Typical Sealant Filled Vertical Joint Detail – Plan

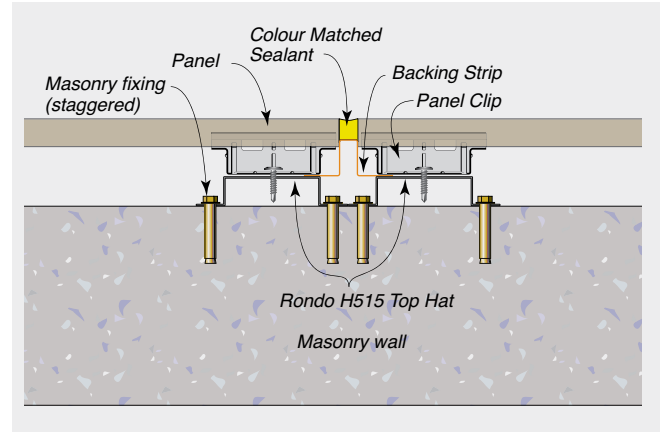

**FIGURE 8.47** Alternative Sealant Filled Vertical Joint Detail – Plan

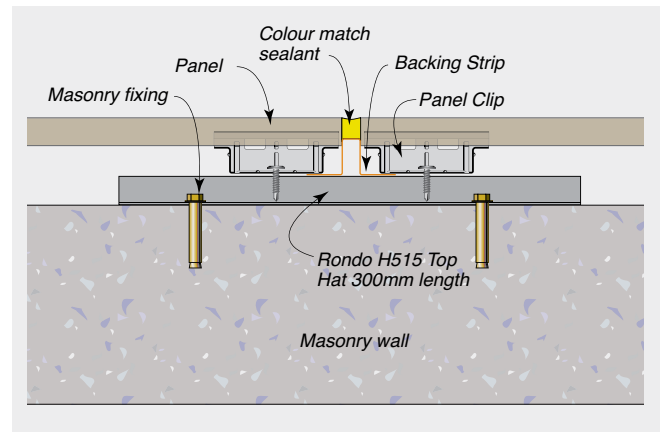

**FIGURE 8.48** Typical Parapet Detail – Elevation

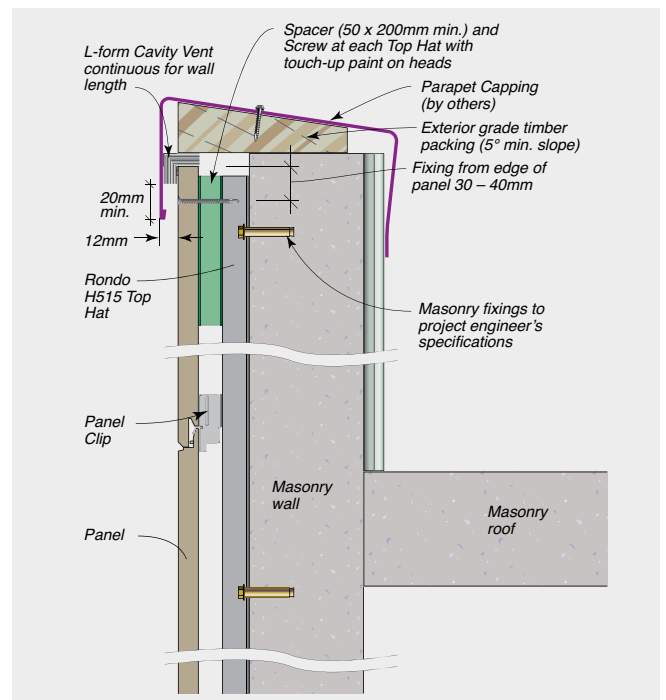



# CONSTRUCTION DRAWINGS AND DETAILS

Note: Drawings are interchangeable for timber or steel substrates with the exception of the fasteners.

## Masonry Windows Details

**FIGURE 8.49** Typical Domestic Window Head, Sill and Jamb Detail

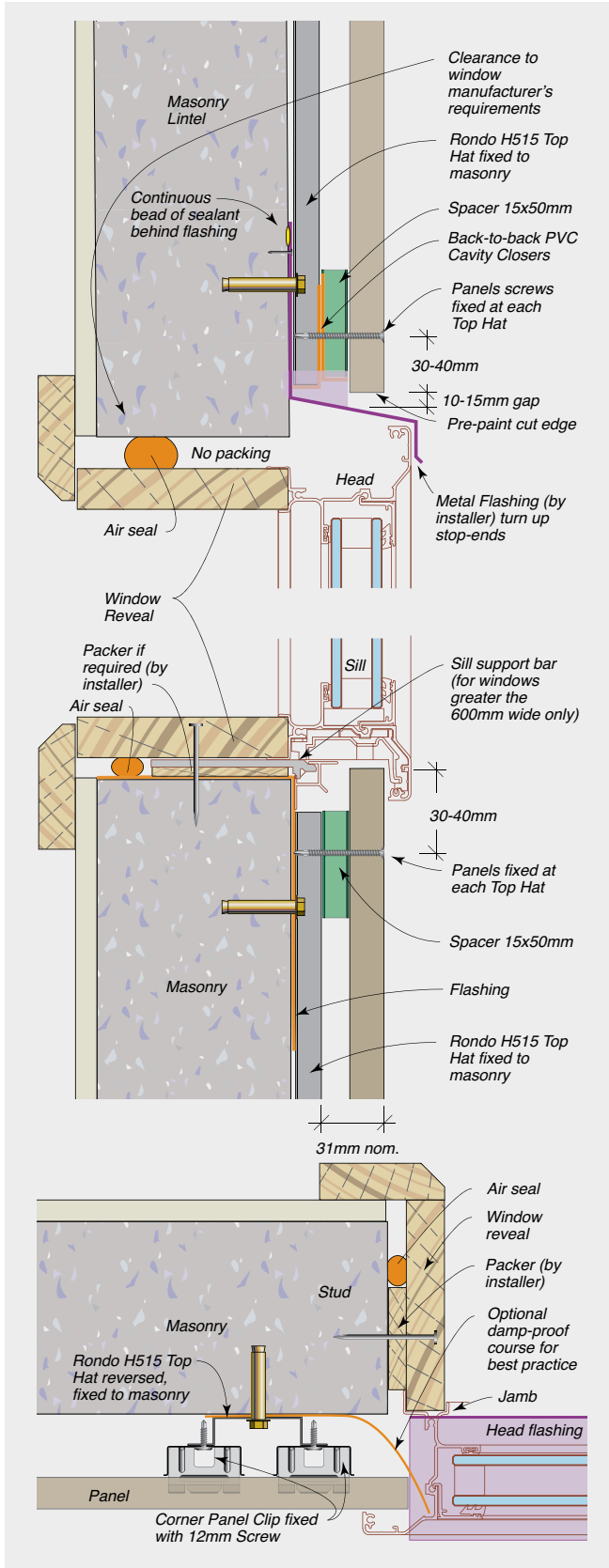

**FIGURE 8.50** Typical Commercial Window Head, Sill and Jamb Detail

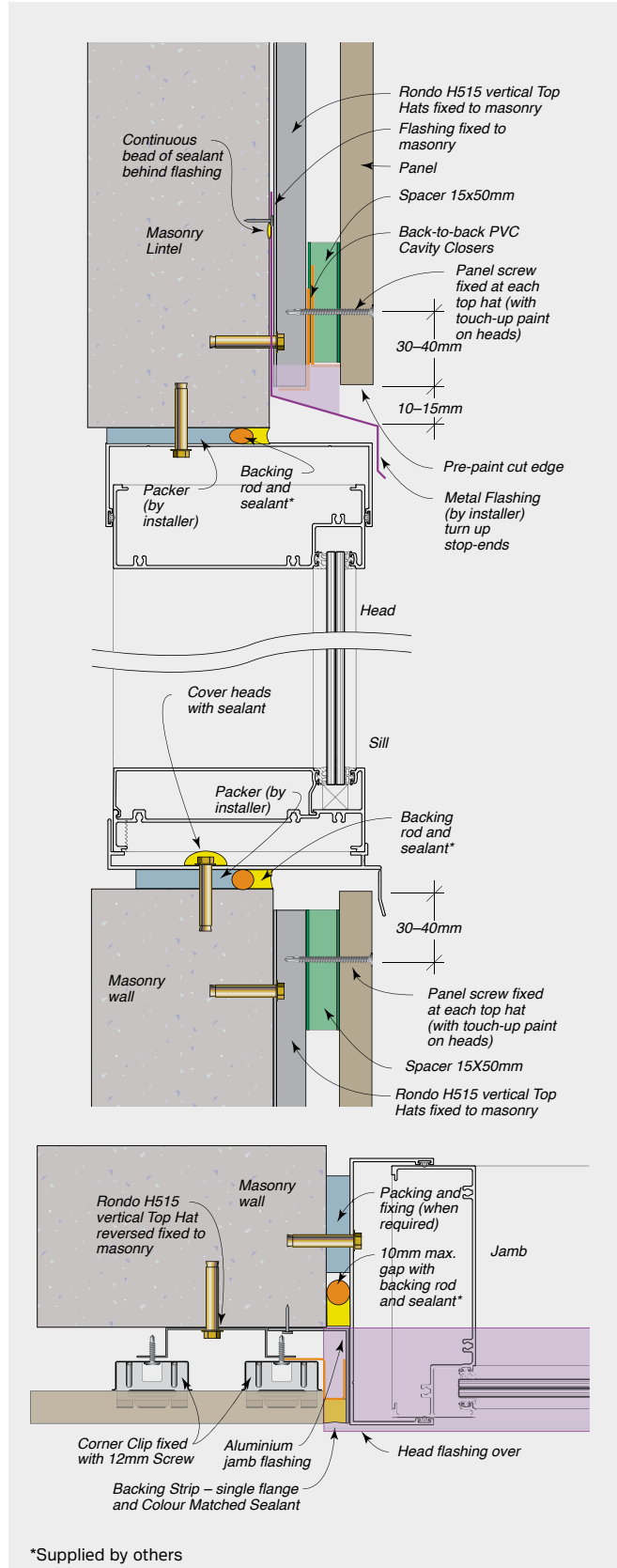



## CONSTRUCTION DRAWINGS AND DETAILS



Note: Drawings are interchangeable for timber or steel substrates with the exception of the fasteners.

FIGURE 8.51 Typical Power Meter Box Installation - Elevation

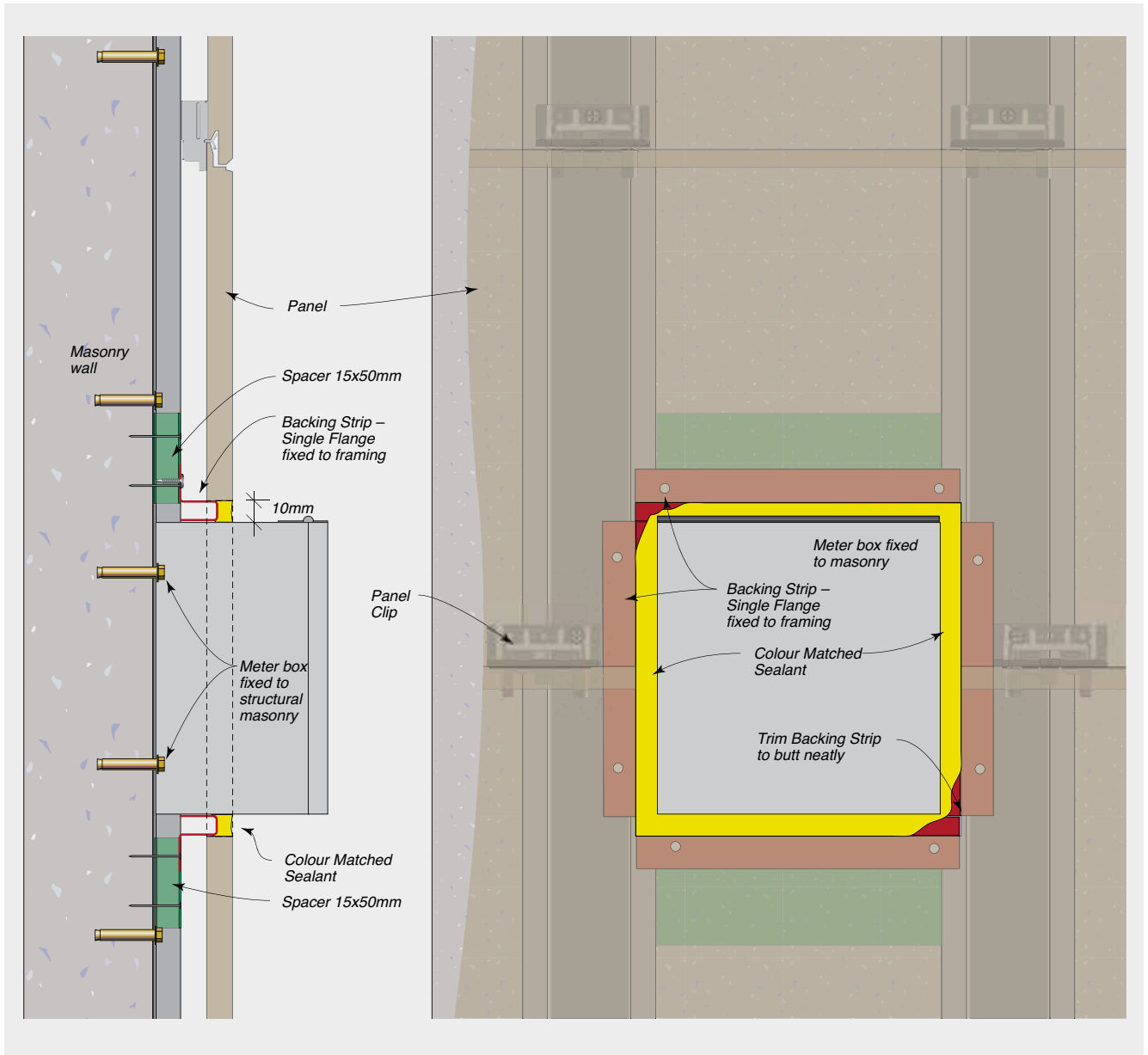





**SAFETY, HANDLING  
+ GENERAL CARE**

## SAFETY, HANDLING + GENERAL CARE



### Health, Safety and Personal Protection Equipment (PPE)

**Panels contain silicas that are harmful if inhaled. Protective clothing and breathing equipment should be worn when cutting products.**

When cutting, drilling or grinding Territory panels using power tools, always ensure the work area is properly ventilated. An approved dust mask (AS/

NZS1715 and AS/NZS1716) and safety glass (AS/NZS1337) must be worn. Cemintel NZ recommends using a dust extraction system. Hearing protection should also be worn.

Safety Data Sheet information is available at [cemintel.co.nz](http://cemintel.co.nz)

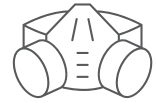

### Recommended Safe Working Practices

|                                  |   |
|----------------------------------|---|
| Cutting Outdoors                 | <ol style="list-style-type: none"> <li>1. Position cutting station so wind will blow dust away from the user or others in the working area.</li> <li>2. Use a dust reducing plunge saw equipped with a dust extraction system.</li> </ol>   |
| Sanding/Drilling/Other Machining | When sanding, drilling or machining, you should always wear a P1 or P2 dust mask and warn others in the immediate area.   |
| Important Reminders              | <ol style="list-style-type: none"> <li>1. <b>NEVER</b> use a power saw indoors.</li> <li>2. <b>NEVER</b> use a saw blade that is not purpose-made for cutting fibre cement products.</li> <li>3. <b>NEVER</b> dry sweep.</li> <li>4. <b>ALWAYS</b> follow tool manufacturers' safety recommendations.</li> <li>5. <b>ALWAYS</b> maintain tools in a clean condition.</li> </ol> |

### Handling & General Care

#### Storage

All Territory panels must be stacked flat, clear of the ground and supported at 300mm maximum centres on a level platform. Panels must be kept dry, preferably stored inside the building. Panels must be dry prior to fixing, hence if it is necessary to store outside, the product must be protected from the weather.

#### Handling

Territory panels and corners are pre-finished products and must be treated with care during handling so as to avoid damage to edges, ends and pre-finished surface. Panels should be carried horizontally on edge by two people.

As the Territory range is a pre-finished product, consideration should be given to the activity of other tradespeople. It is highly recommended that installation of Territory should always be held off until all other claddings have been completed so as to avoid damage.

#### Cutting

Panels should be cut from the back using a power saw. Cemintel NZ recommends using the Makita Plunge Saw or FESTO TS 55 EBQ Plunge Cut Saw with guide rail and appropriate blade. All exposed cut edges such as the window heads and roof junctions must be sealed with Cemintel edge sealer. Refer to 'Components' table for appropriate materials. **Do NOT cut with a wet saw.**

#### Mitreing of Panels

It is not recommended to mitre panels as this can cause delamination of the face.

#### Face Fixing of Panels

At face fixing points, all panels must be supported by a Spacer Strip of 200mm minimum length. Panels must be pre-drilled to accept nails. Use a 2.5mm drill bit and drill from the front. Nail/screw heads should finish flush with the panel surface. All visible nail/screw heads should be neatly covered with primer and colour-matched painted used sparingly. Do NOT use sealant on nail heads.

#### Penetrations

Penetrations in panels may be cut or drilled prior to installation. Cut from the back or drill from the front. Cut penetrations oversize by 8-10mm all around. Mask, prime and fill gaps with sealant in accordance with recommended methods and products.

#### Bevelled Edges

The top edge of panels at window sill level may require bevelling. Cemintel NZ recommends using the FESTO DSC-AGP 125 Diamond Blade Cutting & Grinding Tool.

10  
WARRANTY, CLEANING  
+ MAINTENANCE

## WARRANTY, CLEANING + MAINTENANCE

10

### Warranty

The Cemintel Territory panels have a product warranty of 15 years.

The full Cemintel Territory product warranty is available for download at [cemintel.co.nz](http://cemintel.co.nz)

### Wash Down

When cleaning panels, use no more than 700psi (50kg/cm<sup>2</sup>) of water pressure at 3 to 3.5m distance from the face. Water pressure should be applied downward to avoid forcing water into tongue and groove joints.

Use neutral detergent with a soft brush when removing dirty spots from a panel. When diluting the neutral detergent, follow the manufacturer's instructions, and use the weakest solution possible.

### Graffiti Protection

For walls requiring anti-graffiti protection, Cemintel NZ recommends the application of Watty!® Poly U-400 Anti-Graffiti Clear. Please refer to Watty!® for coating instructions and the warranty conditions of this product.

### Recoating

If recoating in an alternative colour is desired, Cemintel NZ recommends the use of 1 coat of Watty!® Aquaprep Primer Sealer Undercoat and 2 coats of Watty!® Solagard®.

Prior to any recoating, panels should be washed down, as per the maintenance instructions, and

the coating should be applied as per Watty!® instructions.

Cemintel NZ recommends that only Territory Savanna is suitable for recoating with an alternative colour.

### Inspection, Repair and Maintenance

The durability of the Cemintel Territory range can be enhanced by periodic inspection and maintenance. Inspections should include examination of the coatings, flashings and seals. Any cracked or damaged finish or seals which would allow water ingress must be repaired immediately by resealing the affected area, or by removing the panel and replacing sealant. Any damaged flashings, sheets or sealant must be replaced as for new work.

Regularly inspect panel surfaces and follow wash-down procedures when required. Small blemishes can be repaired using touch-up paint or other approved paint.

Ensure ventilation and drainage gaps between panels and flashings are clear of any debris.

It is recommended storing additional panels in case any panels are damaged in the future. Any small chips can be painted over with touch up paint which both hides the underlying panel colour and seals the panel to prevent moisture ingress.

If a whole panel needs to be replaced, the panels which sit above it will need to be removed one by one from the heading, and then reassembled with joints resealed.



Cemintel is a business division of CSR Building Products (NZ) LTD

---

## **Our Office**

### **Auckland**

14 The Furlong  
Takanini  
Auckland

0800 999 277

**[cemintel.co.nz](http://cemintel.co.nz)**

Disclaimer: Information presented in this document is supplied in good faith and to the best of our knowledge, was accurate at the time of preparation. Products are subject to natural variation as part of the manufacturing process. Product images may vary from actual product in regard to colour and surface finish. The provision of this information should not be construed as a recommendation to use any of our products in violation of any patent rights or in breach of any statute or regulation. Users are advised to make their own determination as to the suitability of this information in relation to their particular purpose or specific circumstances. Since the information contained in this document may be applied under conditions beyond our control, no responsibility can be accepted by Cemintel, or its staff for any loss or damage caused by any person acting or refraining from action as a result of misuse of this information.